



# KT-4 Four-Door Controller Installation Guide

Building Technologies and Solutions

[www.kantech.com](http://www.kantech.com)

2024-10-04

A16381A195

Rev. C



A16381A195-C



# Contents

Safety information.....	5
Introduction.....	6
Features.....	10
Operating modes.....	10
Compatibility with EntraPass.....	11
Configuring IP communication.....	11
Communication ports.....	11
IP connectivity: Wi-Fi or wired, and optional PoE+ or PoE++.....	11
AES encryption 128-bit.....	12
Inputs.....	12
Tamper input.....	12
Lock outputs.....	13
Relay outputs.....	13
ioSmart card readers.....	13
Reader outputs.....	13
Reader interfaces.....	13
Integration interface.....	13
Detecting ports automatically.....	13
Downloading firmware.....	13
Trouble and reporting.....	13
Compatibility.....	14
Technical specifications.....	14
KT-4 PCB LEDs.....	16
Vital LED.....	17
Wiring diagrams.....	18
System setup with EntraPass.....	22
Security hardening guide.....	23
Architecture.....	23
Updating to the latest firmware.....	24
Security configuration.....	24
Connecting to a network.....	24
Managing users.....	25
Protecting the network.....	25
Deployment.....	25
Installation.....	26
Preparing to install the KT-4.....	26
Installing the KT-4.....	26
Mounting the cabinet.....	26
Earth grounding.....	27
Connecting door locking devices.....	28

Connecting inputs.....	29
Connecting card readers.....	30
Connecting relay controlled outputs.....	33
Connecting auxiliary outputs.....	33
Connecting a tamper switch.....	33
Connecting the KT-4 over RS-485.....	33
Powering the KT-4.....	36
Powering the KT-4 using PoE+ or PoE++.....	36
Powering the KT-4 using an external transformer.....	37
Powering the KT-4 using an internal transformer.....	37
Reset options.....	38
Soft reset.....	38
Hard reset.....	38
Forced default static.....	38
Factory default DHCP.....	39
Resetting the KT-4.....	39
SPI expansion port.....	40
Configuration.....	43
Configuring the KT-4 using the KT-Finder.....	44
Connecting and configuring a wireless controller.....	44
KT-4 models, expansion kits, and related items.....	45
KT-4 maintenance recommendations.....	47
Technical support.....	47
Compliance specifications.....	49
United States and Canada.....	49
Warning (Part 15.105).....	49
RF Transmitters: Compliance Statement (Part 15. 19).....	50
IC Statement.....	50
Warning (Part 15. 21).....	51
RF Exposure (OET Bulletin 65).....	51
Canada.....	51
CE, RCM, & UKCA.....	52
UL.....	52
End-User License Agreement.....	56
Copyright.....	57

# Safety information

**⚠ WARNING: Risk of Electric Shock.** Do not install the equipment during a lightning storm.

This equipment, KT-4 Four-Door Controller Model KT-4-EU, shall be used installed and used within an environment that provides the pollution degree max 2 and over voltages category II non-hazardous locations, indoor only. The equipment is fixed and permanently connected and is designed to be installed by service personnel only. Service personnel is defined as a person having the appropriate technical training and experience necessary to be aware of hazards to which that person may be exposed in performing a task and takes measures to minimize the risks to that person or other persons. The equipment is installed in a metallic cabinet that meets the applicable requirements for a fire enclosure.

**ⓘ Note:** When installed on the North American Market, powered via the UL, cUL Listed 75VA Transformer, the KT-4 Four-Door Controller shall be connected to the mains by a licensed electrician in accordance with the applicable rules of the National Electrical Code or Canadian Electrical Code regarding this type of connection.

1. The connection to the mains supply must be made as per the local authorities rules and regulations: In the UK as per BS6701. An appropriate disconnect device must be provided as part of the building installation. Where it is not possible to rely on the identification of the neutral in the AC mains supply, the disconnecting device must disconnect both poles simultaneously (line and neutral).
2. Avoid setting up the equipment near heaters, air conditioners, ventilators, and/or refrigerators. Do not select a place that exposes your controller to direct sunlight, excessive heat, moisture, vapors, chemicals or dust.
3. If during the installation a knockout on the cabinet is removed, it is the installer's responsibility to ensure that the same degree of protection for the cabinet is provided by the use of bushings, fittings, adequate sealant, etc.
4. The metallic cabinet must be secured to the building structure before operation. Use four stainless steel tapping screws #8, 32 mm (1.25 in) to mount the cabinet.
5. The ground connection must be as shown within the included diagram, or equivalent.
6. Internal wiring must be routed in a manner that prevents:
  - Excessive strain on wire and on terminal connections;
  - Loosening of terminal; connection
  - Damage of conductor insulation;
  - Reducing the clearance between SELV (Safety Extra Low Voltage) circuits and non-power Limited Circuits (Battery wires);
  - Route the battery wires away from the rest of the SELV circuits.
7. It is the end-user and/or installer's responsibility to ensure that the disposal of the used batteries is made according to the waste recovery and recycling regulations applicable to the intended market.
8. There are no serviceable parts within the equipment; For any issues regarding the equipment, contact your installer.
9. Before leaving the premises, the Ethernet communication lines must first be connected to an approved (acceptable to local authorities) type Network Interface Device (NID), (UL installations, UL 60950-1 or UL 62368-1 listed NID, for ULC installations CAN/CSA C22.2, No. 60950-1 or 62368-1 Certified NID). All wiring shall be performed according to the local electrical codes.
10. Disconnect power before servicing.

# Introduction

The KT-4 four-door controller offers a simple access control and point monitoring solution. The following figures show the KT-4 PCB, inputs and outputs, and cabinets.

**Figure 1: KT-4 PCB**

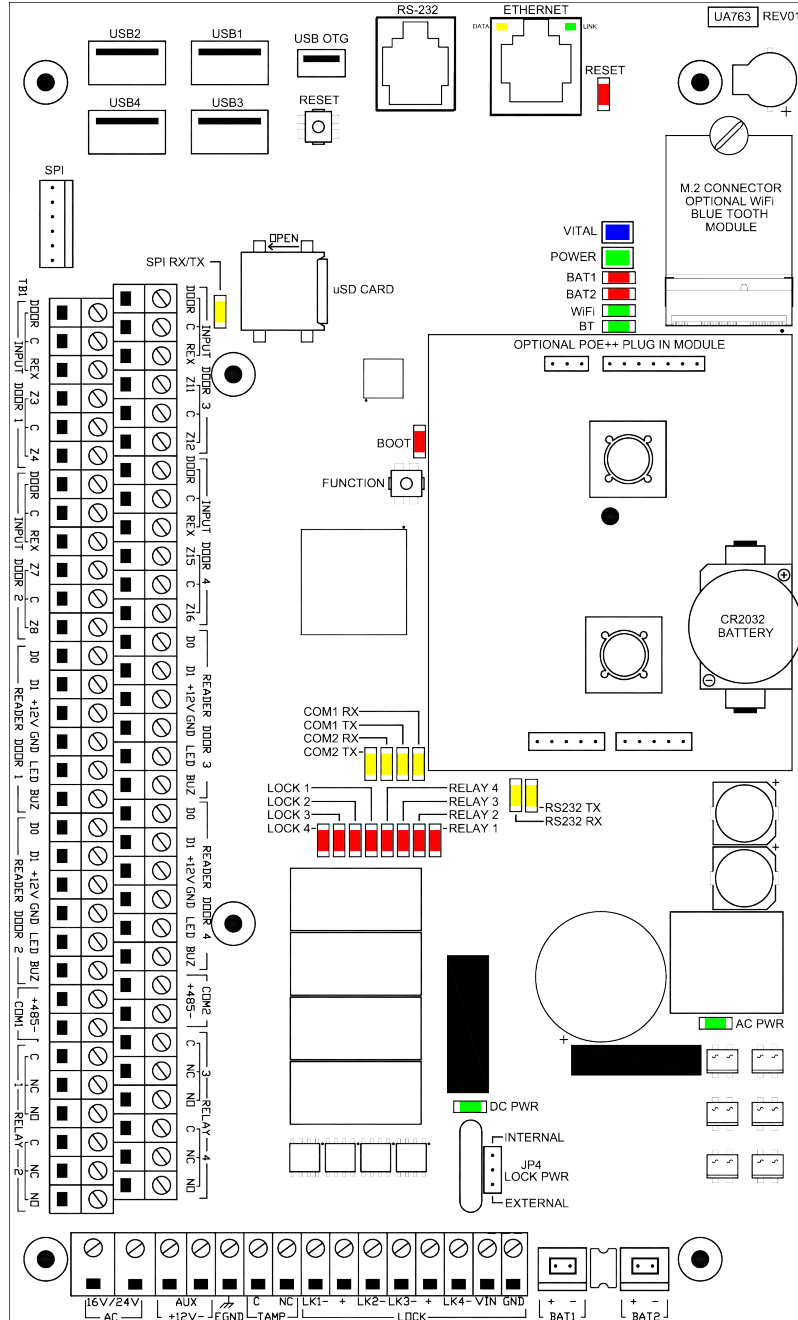

**Figure 2: KT-4 inputs and outputs**

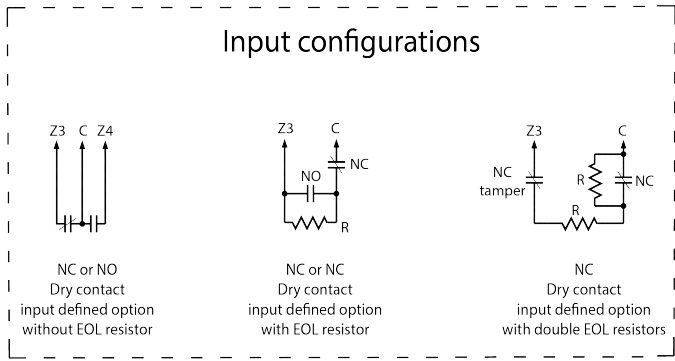
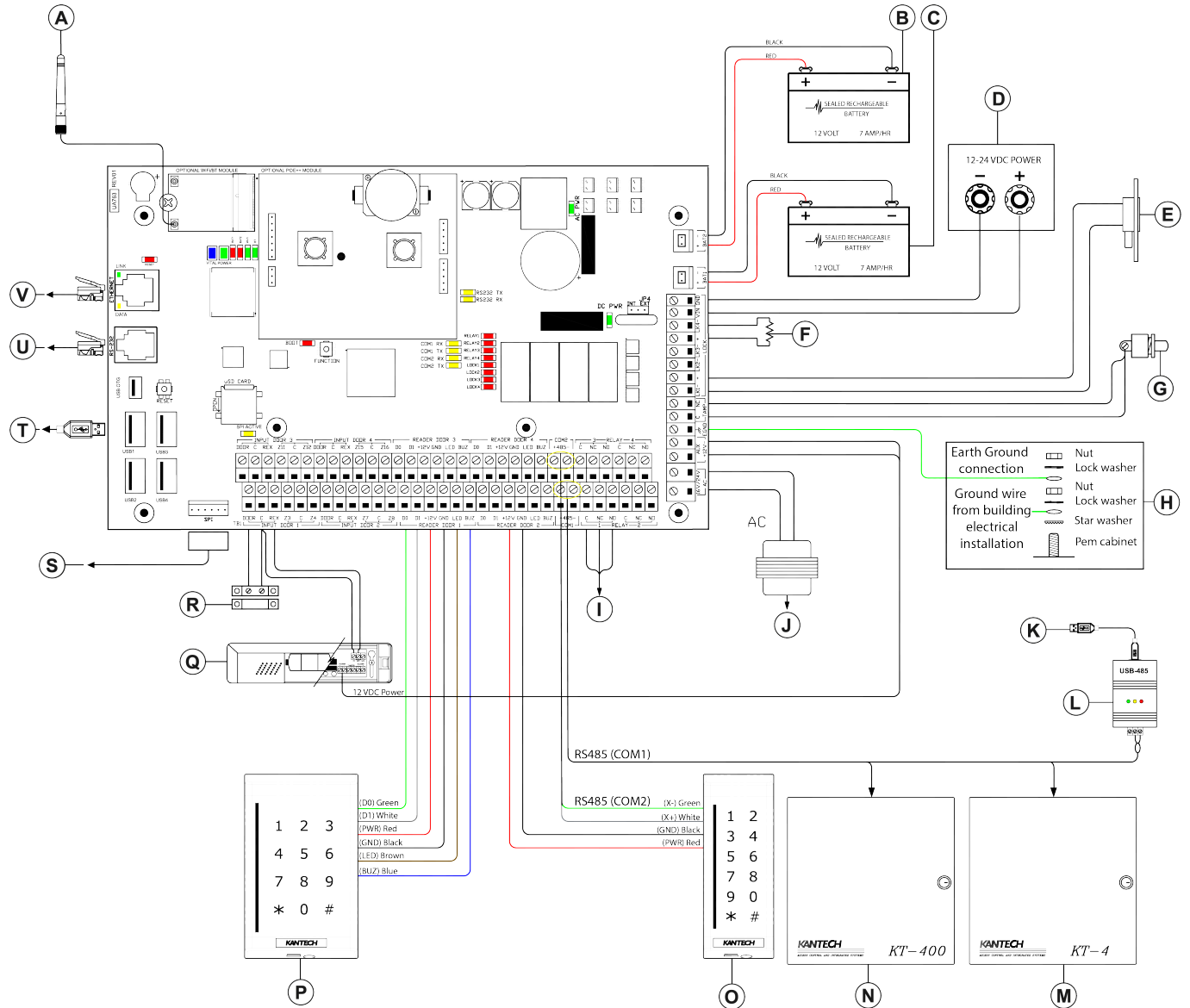

<b>Callout</b>	<b>Description</b>
A	2.4-5 GHz Antenna. Used with optional Wi-Fi module.
B	Optional battery 2: 12 V, 7 A/H
C	Battery 12 V, 7 A/H
D	Optional external power supply for locking device: 12-28 VDC, 4 AMPS maximum jumper JP4 on EXT
E	Door locking device: 12 to 13.75 VDC, 2 A maximum when you use internal power, jumper JP4 on INT
F	Connect a 1K Ohms resistor between LK- and + if you do not use a locking device.
G	Optional tamper switch
H	Tighten the nut to break the paint and ensure a secure connection to the cabinet.
I	Relay 1: 30 VDC, 3 Amps, Form C, four provided
J	Transformer
K	If you do not use Ethernet communication, connect to an EntraPass Gateway USB port. Legacy installations only.
L	Kantech USB-485 USB to RS-485 communication interface
M	KT-4 access controller
N	KT-400 access controller
O	ioSmart mullion reader with integrated keypad on RS485 interface
P	ioSmart single gang reader with integrated keypad on Wiegand interface
Q	Door 1 request to exit device, four provided
R	Door 1 contact, four provided
S	Optional SPI expansion port
T	USB type A connector to supported devices such as USB-485 communication device
U	RJ12 low speed 1200-115200 RS232 serial interface
V	RJ45 Ethernet network 10/100/1000 PoE+, or PoE++ with an installed PoE module



Figure 3: KT-4 cabinet for North America

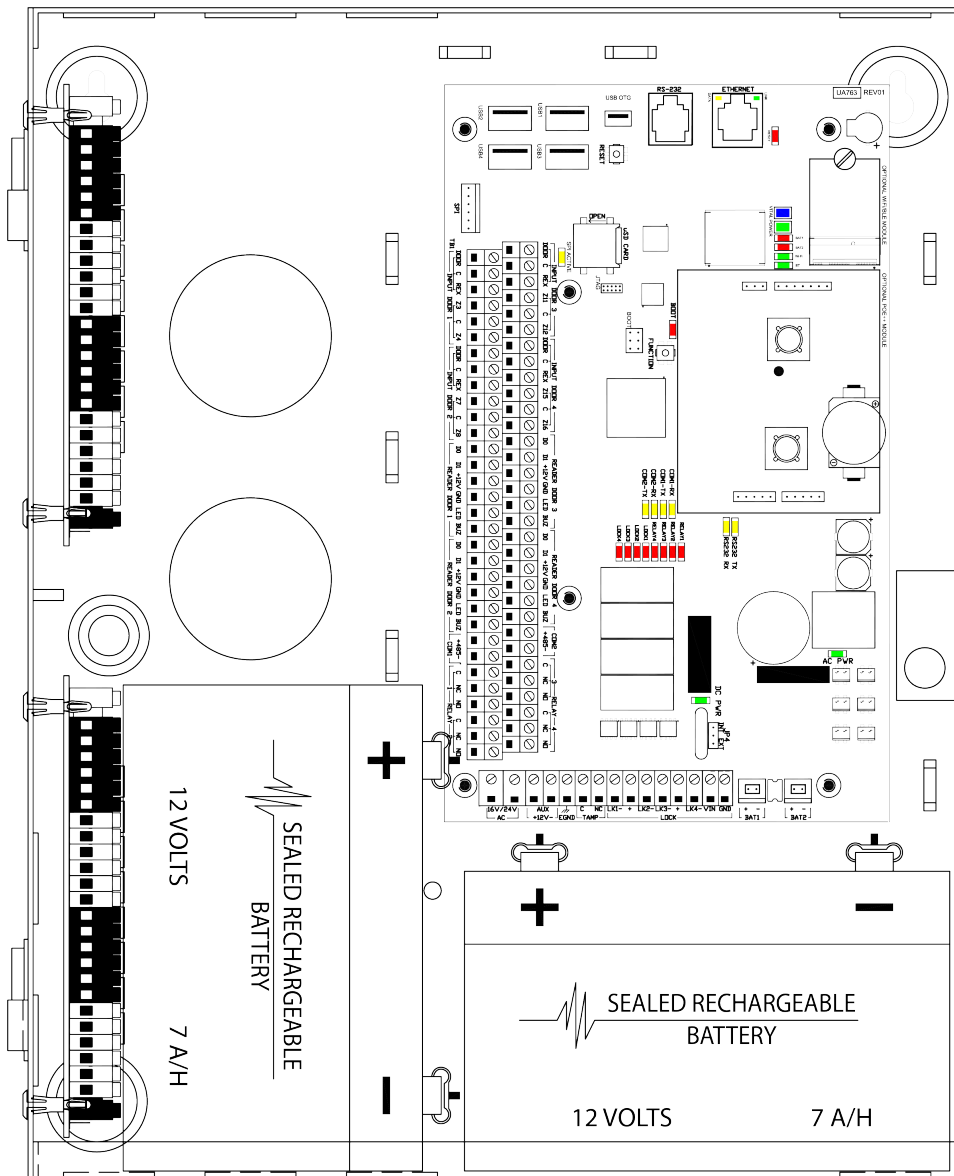



## Compatibility with EntraPass

The KT-4 is compatible with the following EntraPass editions, 8.80 and later:

- EntraPass Special Edition
- EntraPass Corporate Edition
- EntraPass Global Edition with a multi-site gateway or a global gateway

## Configuring IP communication

To configure the controller's IP settings, use one of the following options:

- KT Registration web page
- KT-Finder

For more information, see [Configuration](#).

## Communication ports

The following table lists the KT-4 controller's communication ports.

**Table 1: Communication ports**

Port	Quantity	Use
Wired Ethernet 10/100/1000 Base-T, with optional PoE+ or PoE++	1	For the Ethernet connection
RS-232	1	To communicate and integrate with third party systems ① <b>Note:</b> For UL listed installations, this is only for supplementary use.
RS-485: COM1	1	To communicate with EntraPass or a loop of controllers
RS-485: COM2	1	To communicate with ioSmart card readers or expansion modules, such as the KT-MOD-IO16 Input/Output Module
SPI: 6-pin connector	1	To support bidirectional data exchange with 12 VDC for KT-MOD-REL8, KT-MOD-INP16, and KT-MOD-OUT16 expansion modules

## IP connectivity: Wi-Fi or wired, and optional PoE+ or PoE++

When you use the KT-4 with EntraPass Special Edition, Global Edition, or Corporate Edition software, it can gather its configuration through an IP connection over a local area network (LAN) or over a wide area network (WAN).

① **Note:** Do not use a WAN configuration with EntraPass Global Edition.

When you use the KT-4 with any EntraPass edition, the first controller becomes the main controller and can poll up to 31 controllers. The KT-4 asynchronously polls the KT-1, KT-2, KT-4, or KT-400 controllers, and communicates with the EntraPass gateway only when it is necessary. This reduces the amount of bandwidth that the security system requires to operate on the network.

You can poll up to 8 secondary controllers with EntraPass Global Edition under a KT-NCC, KT-NCC-G2, or Windows Global Gateway. Ensure the following:

- The primary secondary controllers are in the same network
- The primary controller is in IP mode
- The secondary controllers do not have static IPs

- When you configure, provide the serial numbers of the secondary controllers

**Note:**

- Do not use the Ethernet port when the controller is connected to Wi-Fi. If you plug in an Ethernet cable, PoE+, or PoE++, you may experience connectivity issues.
- Avoid PoE (13 W) for powering a KT-4 controller. Standard installation with four controlled doors requires PoE++ (60 W) power source.

## AES encryption 128-bit

When you use the KT-4 over Ethernet, the controller uses 128-bit AES encryption to communicate with the gateway.

AES encryption: NIST compliant

## Inputs

Use the KT-4 controller's sixteen onboard inputs for any of the following functions:

- Door contact
- REX: Request to Exit detector such as T.REX
- Interlock
- Floor selection for elevator application
- Elevator action
- External alarm system status: armed/disarmed
- External alarm system alarm: alarm/secure
- External alarm system zones
- Input actions: relays # to activate on each input in alarm, tamper, or trouble events.
- Zone shunt: shunt a single zone or group of zones, permanently or temporarily, to a secure state on the same controller, or on any other controller if it is operating in KT-NCC mode. For a description of the different shunt methods, see the following list:
  - Manual shunt: the operator can manually shunt a zone into a secure state.
  - Disarmed door shunt: when the alarm system is disarmed, some zones may be shunted to a secure state.
  - Entry/exit delay shunt: when a user disarms or arms the alarm system and an entry or exit delay prevails, some zones may be shunted to a secure state.
  - Zone shunt by another zone: when a zone in alarm is programmed to shunt another zone or group of zones.
  - Zone shunt on unlock: the zone suppresses temporarily to its actual state (alarm or secured) after an access is granted. This is also called no report. See access application.
- Arming/disarming request: the zone is defined as an arming request input.
- Postpone arming request: the zone is defined as a postpone arming request input.

## Tamper input

The tamper input is a non-programmable, fixed-function input that identifies cabinet tampering. You can set up a tamper schedule so that the tamper is supervised only at certain times. You can set up a tamper action to define the relay number to activate the tamper switch in an alarm event.

## Lock outputs

The KT-4 has four onboard lock outputs. You can configure any onboard or expansion module to perform the locking function. Lock outputs are supervised for open circuit or short to ground fault detection.

## Relay outputs

The KT-4 has four onboard relays. The four relays on the KT-4 board and any relays on optional expansion boards that attach through RS-485 are defined as local relay outputs.

## ioSmart card readers

The KT-4 is compatible with ioSmart card readers, which provide security by using end-to-end encryption between the ID badge credentials and the EntraPass software.

## Reader outputs

The KT-4 has four LED and four buzzer open-collector, switch-to-ground reader outputs. Use these outputs for readers 1 through 4 to give the user visual and audible feedback on access events.

## Reader interfaces

The KT-4 has four onboard 12 VDC reader interfaces. You can configure each of the reader interfaces to operate in the following ways:

- Wiegand data over Wiegand
- ABA data over Wiegand
- ABA data over ABA clock and data

## Integration interface

The KT-4 supports alarm panel interfacing when you make the appropriate connections between zone inputs, relay outputs, and the alarm system panel.

## Detecting ports automatically

The KT-4 automatically detects the site communication speed set by EntraPass.

To detect the communication port automatically, in EntraPass, select Wi-Fi, wired Ethernet, or RS-485 (COM1).

## Downloading firmware

To download firmware updates, log on to <http://www.kantech.com>. Click the **Support** tab, click **Software Downloads**, and download the appropriate firmware version.

## Trouble and reporting

The KT-4 monitors its power continuously and reports low and critical power issues. It supervises AC power and battery condition and reports AC lost, normal battery, low battery, battery critical, or no battery statuses to EntraPass. The controller monitors the power outputs and electronically protects them against short-circuits and surges. The controller monitors locking devices to detect open circuit or short to ground faults.

## Compatibility

The KT-4 is optimized for communication with EntraPass v8.71 and higher. The KT-4 is compatible with previous EntraPass versions supporting the KT-400 rev1. Controller features vary based on the specific EntraPass versions. A KT-4 firmware update requires EntraPass v8.71. Integrations such as DSC and Aperio are not compatible with EntraPass v8.71 and lower. Contact your sales representative for integration availability.

## Technical specifications

The following table lists the technical specifications of the KT-4 controller.

**Table 2: Technical specifications**

Type	Description	
AC Power Input (KT-4) Transformer class 2	120 VAC 75 VA in, 16 or 24 VAC out	
AC Power Input (KT-4-EU) Transformer	230 VAC 50 Hz 100 VA in, 16.5 VAC out	
DC Power Input	24 VDC +/- 20% at 3.5 A. Do not use a wire longer than 30 m (98 ft).	
PoE+ and PoE++ ① <b>Note:</b> Standard installation with four controlled doors requires PoE++	Standard supported	PoE+ (802.3at): 25.5 W maximum PoE++ (802.3bt): 62 W maximum
	Total power output	PoE+: 24 V at 1.06 A PoE++: 24 V at 2.58 A
Operating temperatures	For UL listed installations: 0°C to 49°C (32°F to 120°F) indoor use only.	
Humidity level	85% relative humidity non-condensing.	
Cabinet dimensions, Height x Width x Depth	37.59 cm x 30.48 cm x 12.57 cm (14.8 in. x 12 in. x 4.95 in.)	
Weight	KT-4: 4.0 kg (8.82 lb) KT-4-EU: 7.0 kg (15.43 lb)	
Reader types	OSDP, Katech RS-485, Wiegand, proximity, ABA Clock and Data, bar code, magnetic, integrated keypad, and smartcard.	
Reader power output	12 VDC at 500 mA maximum each, protected and supervised.	
Monitored points (zone inputs)	16 monitored points (Z1 to Z16), NO/NC without EOL (DRY), single EOL, double EOL and 1 fixed-function tamper input.	
Points maximum wiring	AWG #22-600 m (2000 ft) For the relevant reader's maximum wiring specifications, refer to the reader's installation manual.	

**Table 2: Technical specifications**

Type	Description
Door strike power supervised	<ul style="list-style-type: none"> <li>• 500 mA each or 2 A total for the KT-4 model AC power 75 VA (JP4 on INT)</li> <li>• 750 mA each or 3 A total for the KT-4-EU model AC power 100 VA (JP4 on INT)</li> <li>• 500 mA each or 2 A total for the KT-4 PoE++ power 60 W (JP4 on INT)</li> <li>• 1 A each or 4 A total for the KT-4 (JP4 on EXT)</li> </ul> Lock outputs are supervised for open circuit or short to ground fault detection.
Auxiliary reader outputs	Four LEDs and four buzzers (BUZ) for each individual door, 25 mA maximum each, open collector outputs
Relay controlled outputs	4 onboard Form C relays, 30 VDC, 3 Amps each, 0.6 power factor
Communication ports	1 x RS-232 with RJ-12, 2 x RS-485, 1 x Ethernet 10/100/1000 Base-T with RJ-45, Wi-Fi.  ⓘ <b>Note:</b> Use the RS-232 for integrations, with a maximum cable length of 3 m (10 ft).
Wi-Fi specifications with optional module	Station mode wireless 802.11 b/g/n (2.4/5 GHz) Access point wireless 802.11 n (2.4/5 GHz)
Network type	IEEE 802.00 b/g/n (Wireless LAN)
Frequency/ Max. E.I.R.P.	2.412-2.472 MHz / ETSI 100 mW, FCC 1 W 5.180-5.825 MHz
Expansion port	1 x SPI 6-pin connector, bidirectional data exchange supported. Supplies 12 VDC, shared with 12 VDC auxiliary port.
Auxiliary power	1 x auxiliary 12 VDC, 500 mA maximum shared with SPI expansion port
Communication speed	1200 to 115200 Bauds (automatic detection) over RS-485. 10/100/1000 Mb/s BaseT over Ethernet. 33 Mb/s over Wi-Fi.
Flash memory	Pseudo single cell 5G eMMC NAND flash for application, storage and standalone event buffer holding 60,000 events.
RAM memory	512 MB DDR3 for application loading and running.
Network autonomy	Distributed data and processing.
Certifications/listing	FCC Part 15.247, SQG-60SIPT FCC compliant to CFR 47, Part 15, Subpart B, Class B Class A UL 294, UL 2610, and ULC/ORD-C1076 IC: 3147A-60SIPT. ICES-003 (A)/NMB-003 (A) CE RCM UKCA EN61000-6-1, EN61000-6-2, EN55032, EN62368-1, EN50130-4 RohS WEEE
AES Encryption	NIST compliant

- ❗ **Note:** The KT-4 restarts automatically after total power loss and keeps its programming after an unlimited time of power interruption. The design uses flash memory to save access rules.
- ❗ **Note:** The KT-4 Wi-Fi performance level depends on the type of router that you use and on the installation environment. You can use the KT-4 Wi-Fi access point mode for configuration. This requires a mobile, tablet, or laptop that has Wi-Fi capability and a web browser.
- ❗ **Note:** You must install a PoE++ module to use PoE+ or PoE++ functions.

## KT-4 PCB LEDs

The LEDs on the KT-4 indicate the controller's network activity, power status, and outputs. The following table describes the status that each LED indicates when it turns on.

**Table 3: LED status indicators**

Name	LED color	Status
ETHERNET LINK	Green	The LED is steady on green if there is an Ethernet network connection. The LED is off if there is no Ethernet network connection or the cable is disconnected.
ETHERNET DATA	Yellow	The LED is blinking yellow if there is network activity.
RX1	Yellow	The LED is blinking yellow if the RS-485 serial port is receiving activity from the gateway.
TX1	Yellow	The LED is blinking yellow if the RS-485 serial port is transmitting activity to the gateway.
RX2	Yellow	The LED is blinking yellow on if the RS-485 serial port is receiving activity from the backplane, ioSmart readers, or expansion modules.
TX2	Yellow	The LED is blinking yellow if the RS-485 serial port is transmitting activity to the backplane, ioSmart readers, or expansion modules.
R1	Red	The LED is steady on red if Relay 1 is activated.
R2	Red	The LED is steady on red if Relay 2 is activated.
R3	Red	The LED is steady on red if Relay 3 is activated.
R4	Red	The LED is steady on red if Relay 4 is activated.
L1	Red	The LED is steady on red if Lock output 1 is activated.
L2	Red	The LED is steady on red if Lock output 2 is activated.
L3	Red	The LED is steady on red if Lock output 3 is activated.
L4	Red	The LED is steady on red if Lock output 4 is activated.
RESET	Red	The reset functions and button feedback are synchronized with the reset buzzer status.
Vital LED	Blue	The LED is blinking blue if the controller is communicating with EntraPass or the controller's IP mode is activated. For more information, see <a href="#">Vital LED</a> .
POWER	Green	The LED is steady on green when the DC level is higher than 12 VDC.
	Yellow	The LED is steady on yellow when the DC level is lower than 11.5 VDC.
	Red	The LED is steady on red when the DC level is lower than 10 VDC.
BAT1	Red	The LED is steady on red if BAT1 is not detected.







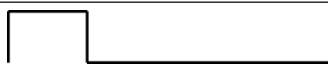
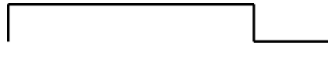

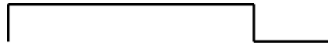

**Table 3: LED status indicators**

Name	LED color	Status
BAT2	Red	The LED is steady on red if BAT2 is not detected.
Wi-Fi	Green	The LED is steady on green when the router is associated with the KT-4, and blinking on Wi-Fi activity.
BT	Green	The LED is steady on green when a Bluetooth device is associated with the KT-4, and blinking on communication activity.
RS-232 RX	Yellow	The LED is blinking yellow if the RS-232 serial port is receiving activity from an integrated device.
RS-232 TX	Yellow	The LED is blinking yellow if the RS-232 serial port is transmitting activity to an integrated device.
AC PWR	Green	The LED is steady on green when AC power is present.
DC PWR	Green	The LED is steady on green when DC power is present.



## Vital LED

The Vital LED shows the controller's communication status and other conditions. Use this information when you connect the controller to the EntraPass system. The following tables describes all possible conditions.

**Table 4: Vital LED patterns**

Condition	LED color	Flashing pattern	
Starting up	Blue	Steady	
Corporate/ Multi-site Gateway	Blue	3 short flashes	
Global Gateway	Blue	1 short flash	
Restarting	Blue	10 flashes every second at 50% duty cycle	
Card read or swipe	Blue	One 0.5 second flash, then it resumes previous flash	
Enrolling	White	1 long flash every 2 seconds	
Acknowledge enrollment	Pink	One 2.5 second flash	
Updating firmware	Green	5 flashes every second at 50% duty cycle	
Receiving broadcast	Green	One 2.5 second flash	
Fail soft	Yellow	Continuous short flashes	

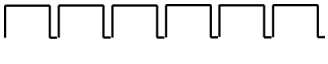
**Table 4: Vital LED patterns**

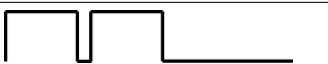
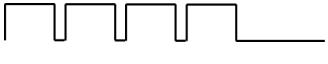
Condition	LED color	Flashing pattern	
Factory default DHCP	Yellow	Continuous long flashes	
Forced default STATIC	Yellow	3 long flashes	
Hard reset	Red	4 short flashes	
Unable to resolve DNS	Red	2 long flashes	
DHCP server failed	Red	4 long flashes	

 **Note:** To reset or change the KT-4 controller's communication mode, see [Resetting the KT-4](#).

## Wiring diagrams

The KT-4 monitors its power continuously, and reports low and critical power issues. Power outputs are monitored and are protected electronically against short-circuits and surges. Locking devices are monitored to detect open circuit or short to ground faults.

Figure 5: KT-4 inputs and outputs, North American model

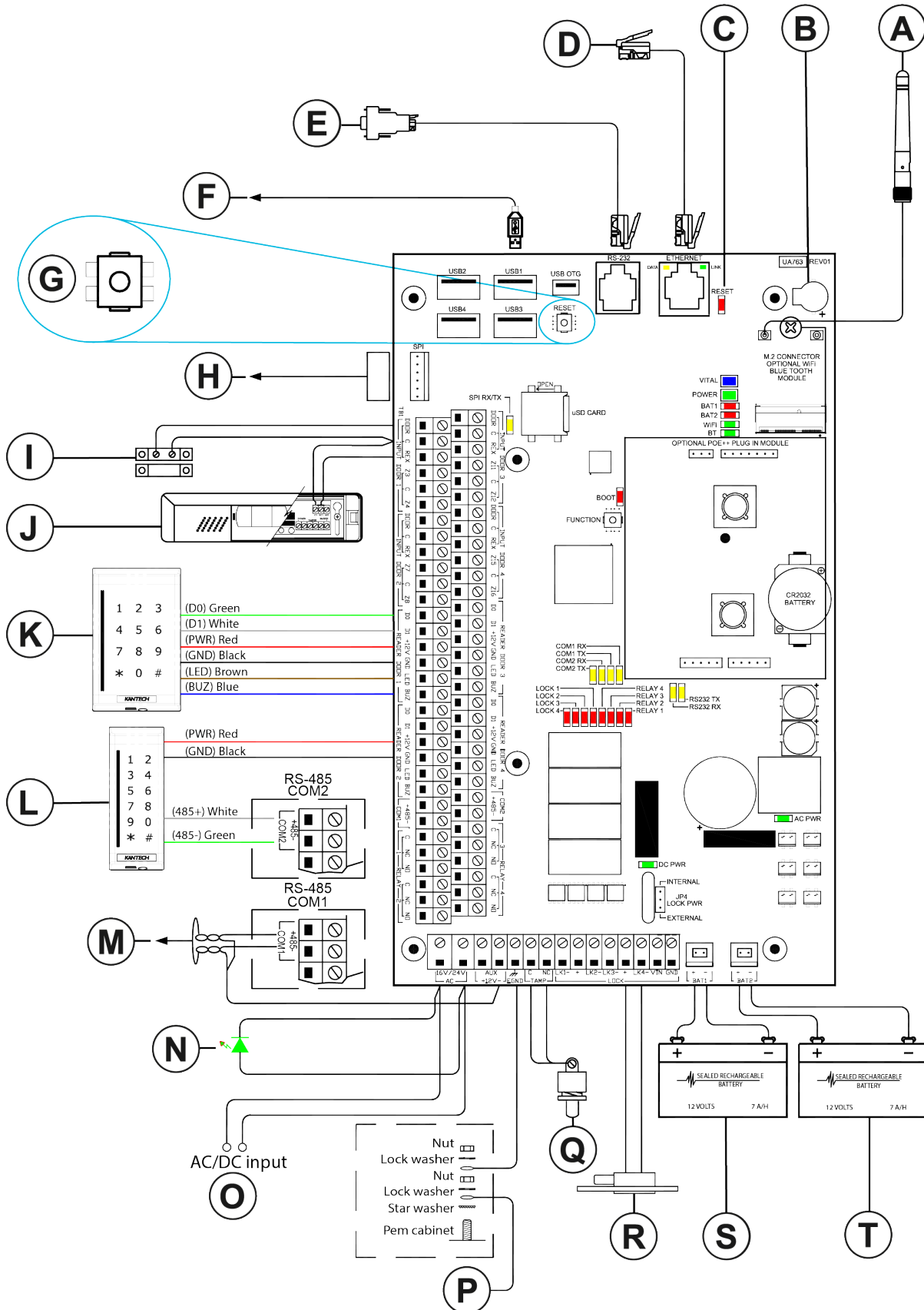

Callout	Description
A	2.4 to 5 GHz antenna. Use with optional Wi-Fi module.
B	Buzzer
C	Reset feedback LED
D	RJ45 Ethernet network 10/100/1000 PoE+ or PoE++
E	RJ12 low speed 1200 to 115200 RS-232 serial interface
F	USB type A connector to supported devices, such as USB-485 communication device
G	Reset switch <ul style="list-style-type: none"> <li>• Press = soft reset</li> <li>• Hold for 3 seconds <ul style="list-style-type: none"> <li>- 1 hit = hard reset</li> <li>- 2 hits = static IP</li> <li>- 3 hits = factory default</li> </ul> </li> <li>• Hold for 3 seconds to confirm</li> </ul>
H	Optional SPI module expansion port
I	Door 1 contact
J	Door 1 request to exit device
K	Door 1: ioSmart single gang reader with integrated keypad on Wiegand interface
L	Door 2: ioSmart mullion or any OSDP reader with integrated keypad on RS-485 interface
M	Connect the RS-485 main network to the next 31 controllers.
N	LED, KT-ACPW-LED
O	AC: 16 VAC to 24 VAC 75 VA, class 2, wire-in 120 VAC at 0.625 A, 60 Hz (75 A) DC: 24 VDC at 3 A <b>Note:</b> Polarity is not important when you connect a DC power supply
P	Ground wire from building electrical installation
Q	Tamper switch
R	Door locking device: 12 VDC, 500 mA maximum. Limited to 2 A if using internal power (JP4 set to INT). Connect a 1K Ohms resistor if you are not using a door locking device.
S	Main battery 12 VDC, 7 A/H, KT-BATT-12
T	Second battery 12 VDC, 7 A/H, KT-BATT-12

## Power supply for North American model

The mains input ratings are 120 VAC/60 Hz 16 or 24 VAC/75VA.

Figure 6: KT-4 inputs and outputs, global model

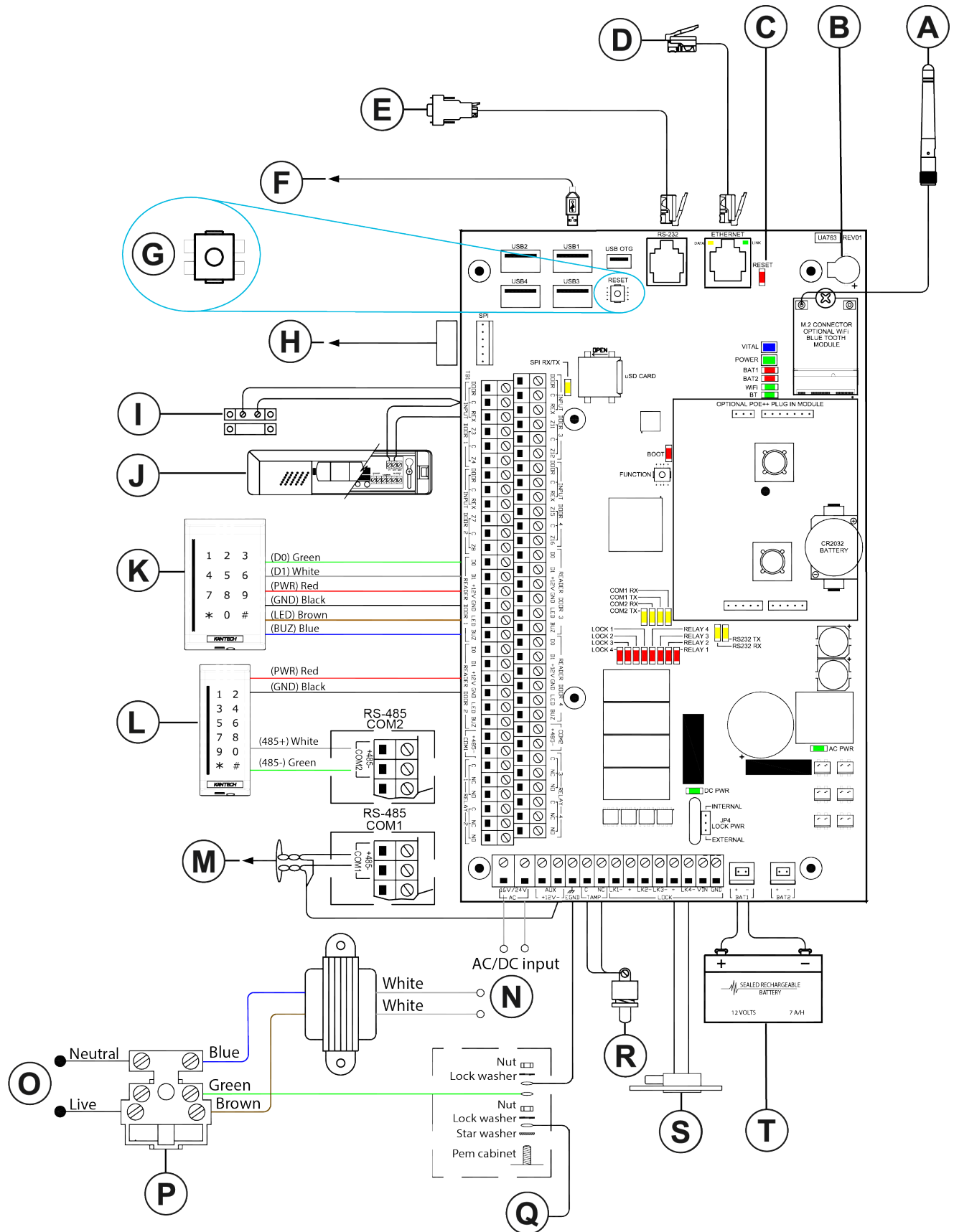

Callout	Description
A	2.4-5 GHz Antenna. Used with optional Wi-Fi module.
B	Buzzer
C	Reset feedback LED
D	RJ45 Ethernet network 10/100/1000 PoE+ or PoE++
E	RJ12 low speed 1200-115200 RS232 serial interface
F	USB type A connector to supported devices such as USB-485 communication device
G	Reset switch <ul style="list-style-type: none"> <li>• Press = soft reset</li> <li>• Hold for 3 seconds <ul style="list-style-type: none"> <li>- 1 hit = hard reset</li> <li>- 2 hits = static IP</li> <li>- 3 hits = factory default</li> </ul> </li> <li>• Hold for 3 seconds to confirm</li> </ul>
H	Optional SPI module expansion port
I	Door 1 contact
J	Door 1 request to exit device
K	Door 1: ioSmart single gang reader with integrated keypad on Wiegand interface
L	Door 2: ioSmart mullion or any OSDP reader with integrated keypad on RS-485 interface
M	Connect the RS-485 main network to the next 31 controllers.
N	AC: 230 VAC, 100 VA 16.5 VAC out transformer DC: 24 VDC at 3 A
O	Mains: 230 VAC, 0.44 A, 50 Hz (100 VA)
P	Fuse: 20 mm 230 VAC, slow blow 630 mA, time-lag TUV or VDE approved
Q	Ground wire from building electrical installation
R	Tamper switch
S	Door locking device: 12 VDC, 500 mA maximum. Limited to 2 A if using internal power (JP4 set to INT). If you are not using a door locking device, connect a 1K Ohms resistor.
T	Main battery 12 VDC, 7 A/H, KT-BATT-12

## Power supply for global model

The mains input ratings are 230 VAC/50 Hz.

**Note:** The KT-4 global model is not validated by UL.

## System setup with EntraPass

You can configure the KT-4 with EntraPass Special Edition, Corporate Edition, or Global Edition software in a number of ways.

When you use the KT-4 with EntraPass Special Edition, Corporate multi-site gateway, or Global Edition gateway, you can configure the setup in the following ways:

- Over Wi-Fi with the optional Wi-Fi module, antenna, and antenna mounting kit
- Over Ethernet
- Over the RS-485 with a USB-485 or VC-485

When you use the KT-4 with EntraPass Global Edition and a KT-NCC-G2, you can configure the setup in the following ways:

- Over the local area network (LAN)
- Over the RS-485 with a VC-485

## Security hardening guide

The security hardening guide provides information about the following areas:

- Assuring compliance with the cybersecurity criteria that govern the target environment
- Designing safe and secure deployment architecture
- Providing a reference for settings that you configure during deployment

To ensure the safe and secure deployment of the KT-4 controller, complete the following steps:

1. Ensure that you understand and plan your controller architecture. For more information, see [Architecture](#).
2. After you complete your architectural plan, install the controller and make application-specific configuration changes. For more information, see [Deployment](#).

## Architecture

The KT-4 architecture includes the following components:

- The KT-4 controller that you can configure in one of two modes:
  - Stand-alone mode: use as a stand-alone access device with an Ethernet connection for direct configuration.
  - EntraPass mode:
    - Wired: use the Ethernet or RS-485 port to connect the controller to the network with access to the EntraPass gateway to establish communication with the EntraPass software.
    - Wi-Fi: use the built-in access point (AP) to connect the controller to a Wi-Fi network with access to the EntraPass gateway to establish communication with the EntraPass software.
- The controller commonly has at least one reader connected to it. You can connect multiple readers and input/output modules to the controller.

See the following guidelines that relate to your chosen controller architecture.

### Connecting to EntraPass using RS-485

If you connect the controller to EntraPass using an RS-485 bus, the connection is not encrypted or authenticated.

- Ensure that you isolate and secure the connection wires inside the walls of the installation in a safe area.
- Ensure that you cannot access wires from an exterior wall.

### Connecting to EntraPass using Ethernet

- To connect the controller to EntraPass in TCP mode, even if the link is encrypted and secure, use a LAN or VLAN.

**Note:** The controller does not support the direct use of a VPN. Connect a VPN through a router.

## Connecting to EntraPass using Wi-Fi

- Ensure that the Wi-Fi connection is encrypted.
- Use a strong Wi-Fi password.

## Connecting a stand-alone controller using Ethernet

- To connect a stand-alone controller, configure your user name and password. Use these details to access the secure Kantech registration web pages to configure the controller.

**ⓘ Note:**

- Do not use `kantech` in the name or password.
- Complete this process during the initial setup.

## Connecting a stand-alone controller using Wi-Fi

- Ensure that the Wi-Fi connection is encrypted.
- Use a strong Wi-Fi password.

## Connecting readers using Wiegand and modules using SPI

The Wiegand connections and SPI connection are not encrypted or authenticated. If you connect readers and modules, complete the following steps:

- Ensure that you isolate and secure the connection wires inside the walls of the installation in a safe area.
- Ensure that you cannot access wires from an exterior wall.
- Use a tamper contact to signal an alarm if someone tries to breach security.

## Connecting readers and modules using an RS-485 bus (with encrypted protocol)

- Connect readers and modules, such as the ioSmart card reader, that interconnect with an encrypted and secure 485 link. These devices include a mechanical or optical contact alarm that does not require additional wires.
- OSDP support: OSDP version 2.2 compliant. EntraPass 8.70 and later supports OSDP.

## Updating to the latest firmware

To ensure your controller has up-to-date security features, use the latest available firmware version.

## Security configuration

You can view, monitor, and access the controller in one of three modes: stand-alone, with EntraPass, or with the cloud service.

If it is required, as you complete the installation wizard, you are prompted to reconfigure your user account, activate additional password security measures, or disable the access point mode.

## Connecting to a network

Depending on your configuration and deployment architecture, you may require network access. For a convenient stand-alone deployment, you can configure the KT-4 over the network.

- When you connect to the network, use a private LAN.



## Managing users

Follow best practice guidelines for managing user accounts, credentials, and permissions. Best practice guidelines include the following:

- Do not share accounts.
- Change passwords every 90 days.
- Create strong passwords. Passwords must contain at least eight characters, and include one lowercase, one uppercase, one number, and one special character.
- Give users access only to what they need.
- Set temporary accounts to expire after a set amount of time.

## Protecting the network

- When the trust deviation is beyond the risk tolerance, control the flow of data between trusted and untrusted networks by using a switch or a router with data flow control capabilities, such as a firewall.
- Isolate the KT-4 system from networks of lower trust.

## Deployment

To ensure the safe and secure deployment of the KT-4, see the following guidelines:

- [Restricting physical access to the controller](#)
- [Logging on during the initial startup](#)
- [Resetting to factory default](#)
- [Knowledge level](#)

### Restricting physical access to the controller

If you install the controller in an area that is easily accessible, this enables actions that cannot be authenticated or logged electronically and may impact the controller's cybersecurity capabilities.

To restrict unauthorized access to the controller, complete the following steps:

- Install the controller in a room, cabinet, or enclosure that you can restrict access to, for example, by using a mechanical lock or other physical access control.
- Configure the controller's mechanical tamper switch to send and log alerts if the device is tampered with.
- Use protective electric wire conduits when communication wires pass through areas of lower trust.

For more information about installing the KT-4, see [Installation](#).

### Logging on during the initial startup

To facilitate common commissioning tasks when you first start up the controller, the following functions are enabled: KT Registration web page and controller discovery. There is no default user account to access these functions.

- To log on to the controller during the initial startup, use the secure account activation process.

### Resetting to factory default

- If the controller was used previously as part of another installation or test environment, reset it to factory default before you use it in the current installation. To reset the controller, see [Resetting the KT-4](#).

## Knowledge level

- To execute the proper hardening steps, you must have experience with KT-4 administration and networking technologies. To gain the required competencies, complete the basic and advanced Kantech installation courses. For more information, refer to <http://www.kantech.com>.

## Installation

Use this section to prepare for the installation, to install the controller, and to connect all of the components.

### Preparing to install the KT-4

Before you install the KT-4, follow these guidelines:

- Install the KT-4 indoors in a secure location with normal temperature and humidity levels.
- Install the KT-4 away from electrical and communication devices.
- When you mount the KT-4, ensure that there is 9 in. (23 cm) of clear space around all sides of the unit and a minimum of 13 in. (33 cm) of clear space in front of the unit.
- If you use Wi-Fi connectivity, avoid metallic surfaces near the antenna location.
- Locate the controllers close to the controlled doors.
- Do not locate the controller within 6.5 ft (2 m) of any high voltage equipment or wiring or any electrical equipment susceptible to generating electrical interference, within 3 ft (1 m) of any telephone equipment or lines, and within 26 ft (8 m) of any third party transmitting equipment.
- Locate the controller so that it is easily accessible to service the equipment.
- Provide physical access by using keys on controlled doors.

### Installing the KT-4

**⚠ WARNING:** Route and secure all internal wiring using tie wraps or equivalent means to ensure that the cables do not come into contact with the front cover of the metal enclosure. Failure to do so may result in risk of physical injury to persons, or damage to or destruction of property.

1. Before you wire the terminal connections, disconnect the power supply.
2. Connect the devices that you require, for example, door locking devices, card readers, and inputs. For more information, see the following sections.
3. Connect the 16 or 24 VAC output from the 120 VAC 75 VA transformer with a KT-4, or the mains 230 VAC with a KT-4-EU. Alternatively, use a 24 VDC at 3.5 A power supply. If powered over Ethernet, connect the PoE+ or PoE++ to the RJ-45 connection.

### Mounting the cabinet

This guide does not provide exact mounting instructions because applications and facilities vary. The surface on which you mount the cabinet at your site determines the type of hardware that you require to fasten the cabinet into position. Use wall anchors that are appropriate for the wall surface.

When you mount the cabinet, follow these guidelines:

- Mount the cabinet on a wall or other surface in a restricted-access area.
- Mount the cabinet flat against a vertical surface with the hinge to the left.
- Locate the cabinet in a position that allows the door to swing open fully to the left.
- Locate the cabinet in a position that allows air to flow over the exposed surfaces.

- Follow the environmental requirements, as [Table 2](#) outlines.

To mount the cabinet, use the four mounting holes as the following figure shows. For optimal results, use #10 (5mm) by 1.8 in (45 mm) long.

**Figure 7: KT-4 cabinet dimensions and mounting holes, in. (mm)**

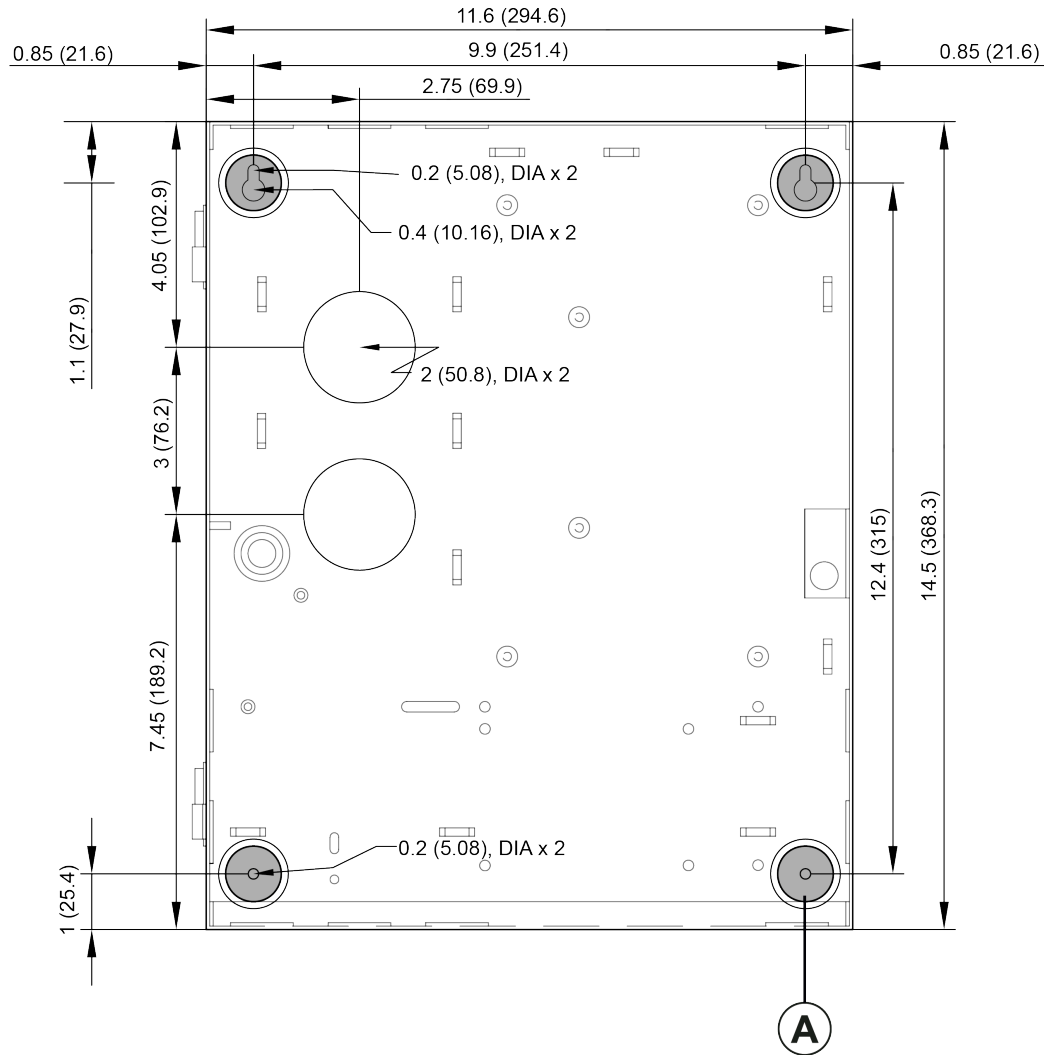

Callout	Description
A	Mounting hole, four total

## Earth grounding

To ensure that the KT-4 controller operates effectively, provide earth grounding.

- Connect the 18 AWG ground wire to the corresponding earth ground terminal.
- Make an earth ground connection to the cabinet of the controller.

**Note:** Follow the requirements of your local electrical code.

- Wire the E-GND terminal on the controller's printed circuit board directly to the earth ground connection point.

## Connecting door locking devices

Connect the door lock device to one of the following:

- + and LK1-
- + and LK2-
- + and LK3-
- + and LK4-

► **Important:** Controlled door locking devices may be governed by regulatory bodies. Always install controlled door locking devices according to local regulations. In most instances, there are strict limitations for emergency exit doors when installing fail-secure and fail-safe locking devices, such as magnetic locks or other similar locking devices.

### Notes

- The door locking device outputs can operate DC-powered locking devices such as electromechanical strikes. You can configure them to operate in fail-safe or fail-secure mode, normal or reverse action.
- If required, you can program any of the controller relays to provide galvanically-isolated outputs.
- If you need external power for all of the external locks, you can use an external power supply. Connect the power supply to the VIN and GND terminals and put jumper JP4 on EXT.

**Figure 8: Door lock setup**

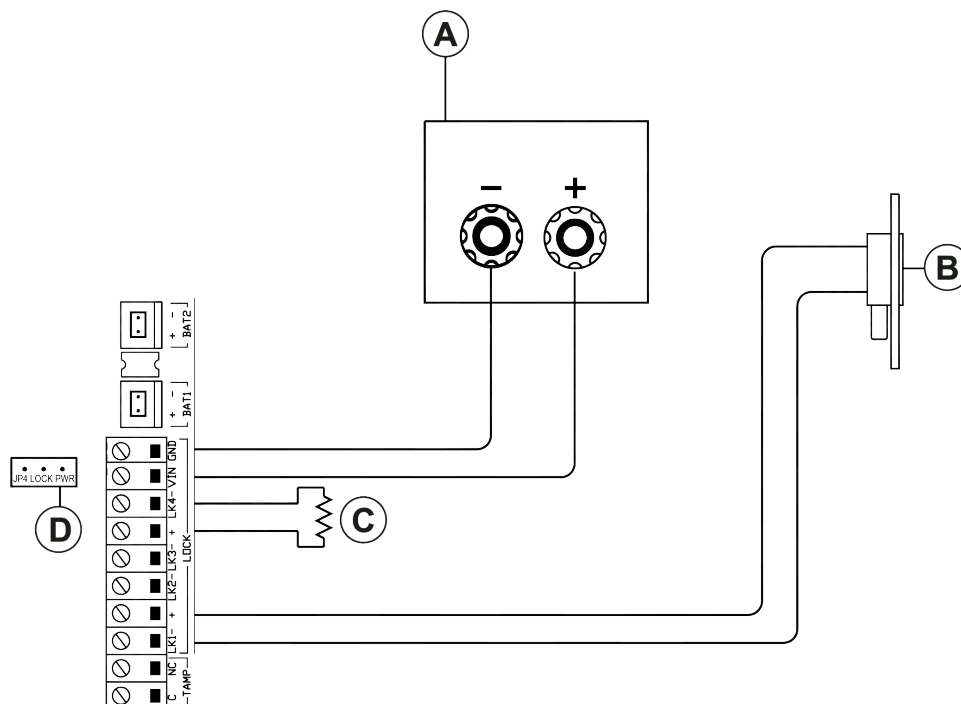

Callout	Description
A	External power supply: 12 VDC to 24 VDC
B	Door locking device: 12 VDC to 13.75 VDC 1.5 A maximum when using internal power, jumper JP4 set to INT. Connect a 1000 Ohms resistor when you do not connect a door locking device.

Callout	Description
C	Connect a 1000 Ohms resistor between LK- and LK+ when you do not use a door locking device.
D	External: When jumper JP4 is on EXT, the total maximum current draw is 12-28 VDC, 4.0 A for all configurations with external power supply.

## Connecting inputs

The KT-4 controller can monitor sixteen inputs. Each onboard input is supervised with or without 5.6K ohm end-of-line (EOL) resistors. The maximum distance of one line is 2,000 ft (600 m) with AWG #22 in a single or double EOL configuration.

1. Connect devices to inputs 1 to 16.
2. Define onboard inputs with none, single, or double EOL resistors.

① **Note:** For UL listed installations, you must use supervised EOL resistors.

Inputs 1 and 2 are automatically reserved for controller door number 1. Inputs 5 and 6 are automatically reserved for controller door number 2. Inputs 9 and 10 are automatically reserved for controller door number 3. Inputs 13 and 14 are automatically reserved for controller door number 4.

**Table 5: Automatic input assignments**

Door	Door contact	Request to exit detector
1	Input 1	Input 2
2	Input 5	Input 6
3	Input 9	Input 10
4	Input 13	Input 14

① **Note:** You do not have to follow this convention but it facilitates servicing.

**Figure 9: KT-4 inputs**

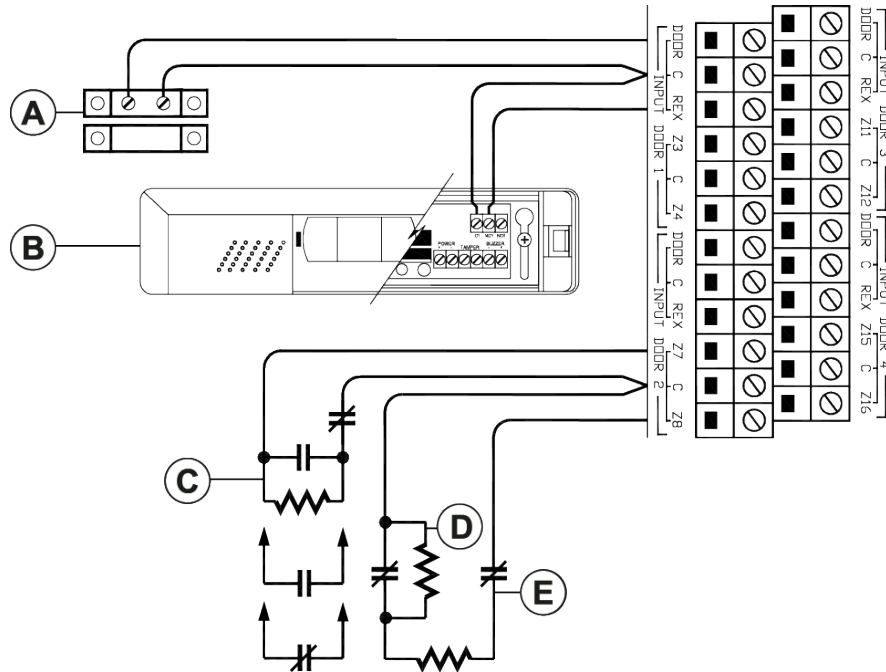

Callout	Description
A	Door 1 contact
B	Door 1 request to exit device
C	Individually programmable zone termination: NC, NO, NEOL, single or double EOL termination.
D	Alarm
E	Tamper

## Connecting card readers

You can connect up to eight readers to a KT-4 controller. The controller provides 12 VDC power for card readers. The maximum distance between the readers and the controller varies by reader type. For more information, refer to the card reader Installation Guide.

- Install one reader to control the entry of a single door.
- Install two readers to control the entry and the exit of a single door.

Figure 10 shows how to connect two readers using a Wiegand or RS-485 configuration. Figure 11 shows how to connect two readers using a daisy-chain RS-485 configuration.

**Figure 10: Wiegand or RS-485 reader configuration**

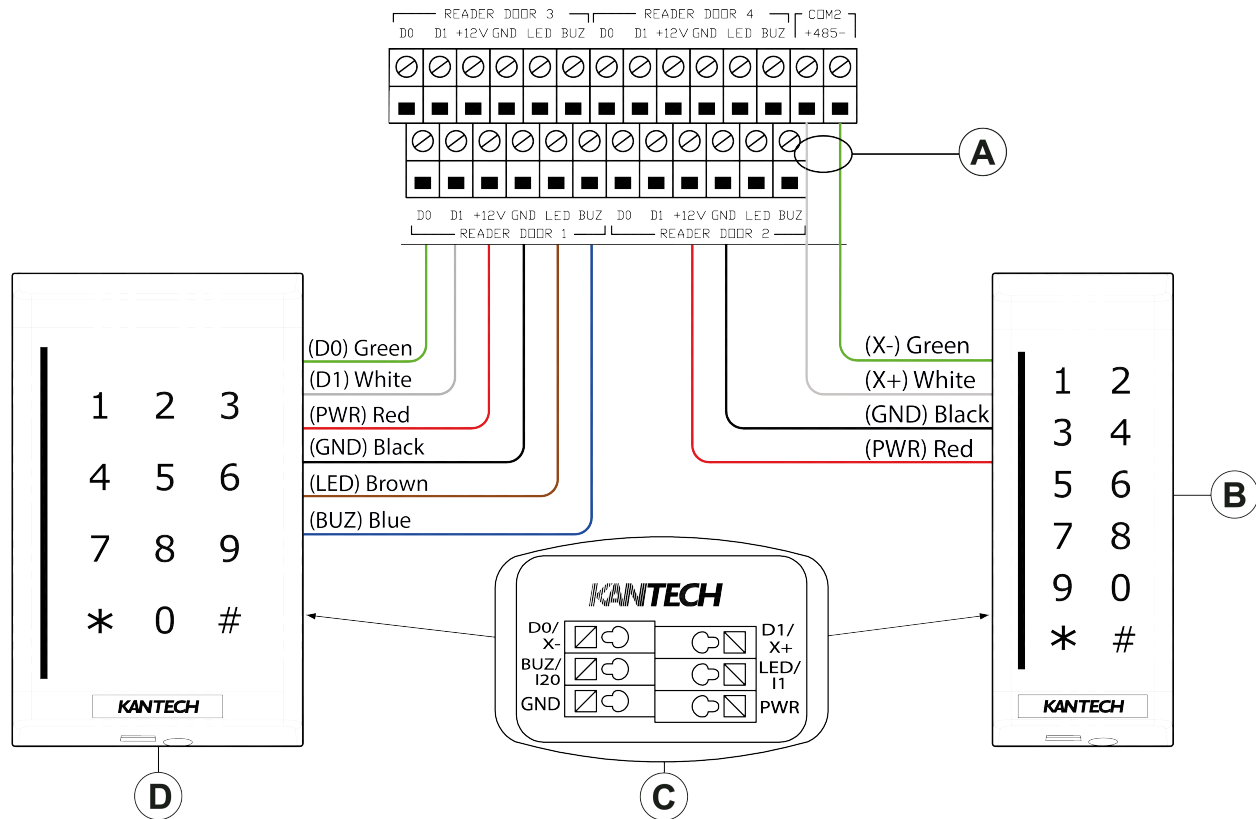

Callout	Description
A	COM2: RS-485
B	ioSmart mullion reader with integrated keypad on RS485 interface
C	Rear view of the reader
D	ioSmart single gang reader with integrated keypad on Wiegand interface

**Figure 11: RS-485 daisy chain configuration**

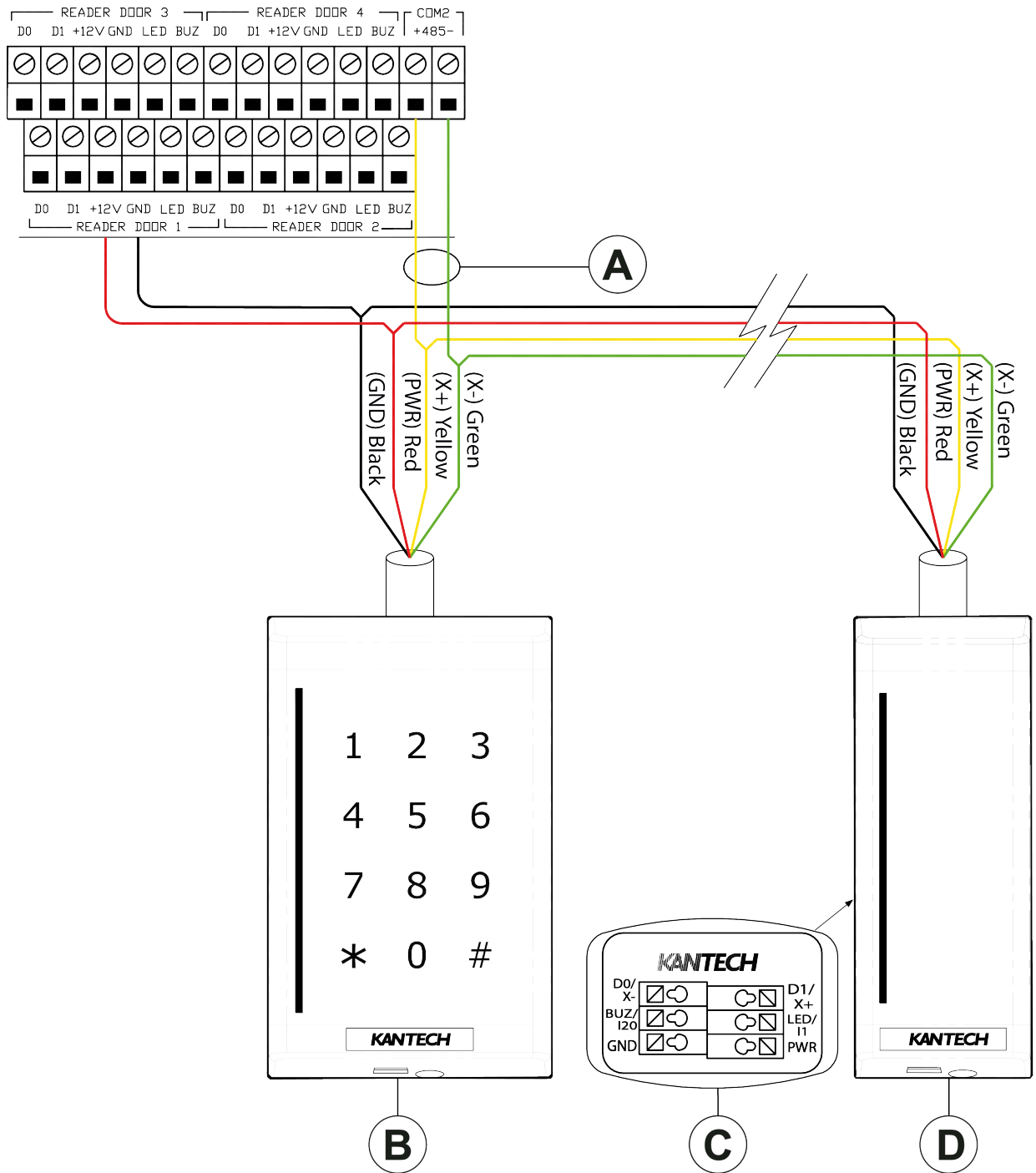

Callout	Description
A	COM2: RS-485
B	ioSmart reader 1
C	Rear view of the reader
D	ioSmart reader 8



## Connecting relay controlled outputs

The KT-4 controller provides four Form C relays that are rated at 3 Amps, 30 VDC, 0.6 power factor.

**Figure 12: KT-4 relay controlled outputs**

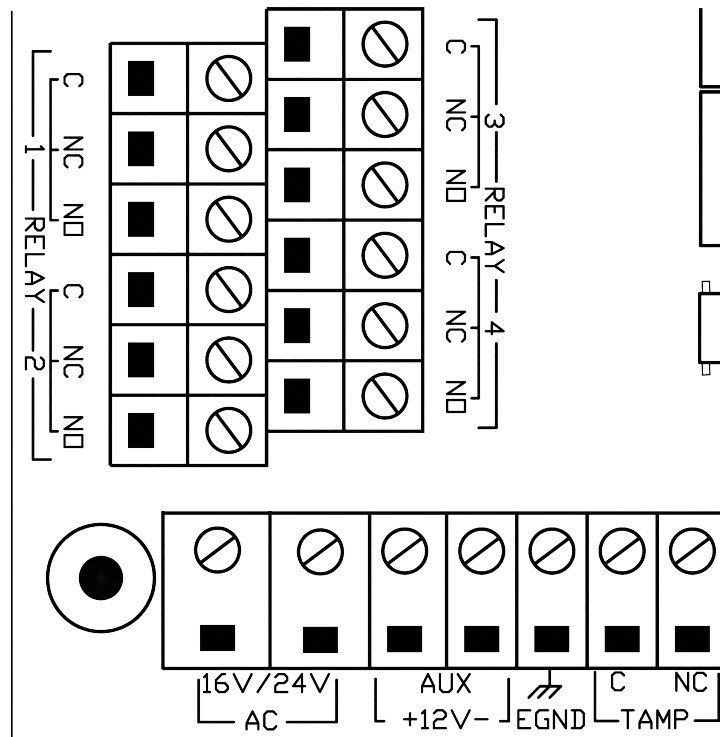

## Connecting auxiliary outputs

### Connect auxiliary outputs to readers and local warning devices

Auxiliary outputs are used for visual and audible signals. You can activate them according to input conditions or events and local alarms. Auxiliary outputs READER DOOR 1 to 4 - LED provide visual feedback of access operations, and auxiliary outputs READER DOOR 1 to 4 - BUZ can activate audible warning devices, such as T-REX or reader buzzer, to signal door alarms.

## Connecting a tamper switch

### Install a tamper switch on the cabinet

A tamper switch must be installed on the unit to detect unauthorized cabinet opening. The normally closed tamper switch must be connected to the dedicated tamper input, next to the EGND.

## Connecting the KT-4 over RS-485

► **Important:** Do not connect several KT-4 controllers at a single point. Do not use splitters or spider web networks at a single point.

① **Note:** On the last KT-4 controller of a loop, there is no end-of-line resistor to install on the RS-485 COM1 terminals.

1. Connect the RS-485 cable to (COM1) X+, X-. The RS-485 terminals link the controllers together.

- ① **Note:** The maximum communication loop length is 4,000 ft (1.2 km) using the appropriate cabling.
  - ① **Note:** If the VDC AUX- is already in use, connect the RS-485 signal ground to the other GND terminals on the KT-4. You cannot use the EGND terminal for signal ground. Only use the GND and AUX 12 VDC negative terminals for signal ground.
2. Wire the RS-485 communication loop with an Ethernet Category 3 double twisted pair (unshielded) network cable or better.
    - ① **Note:** The RS-485 loop can operate from 1200 to 115200 Bauds under normal conditions.
  3. **Optional:** If you experience intermittent communication problems or erratic operation, drop your network speed to a Baud rate of 9600 or 19200. If you vary the network speed, the operating speed of the system does not change noticeably.

Figure 13: Connecting the KT-4 over RS-485

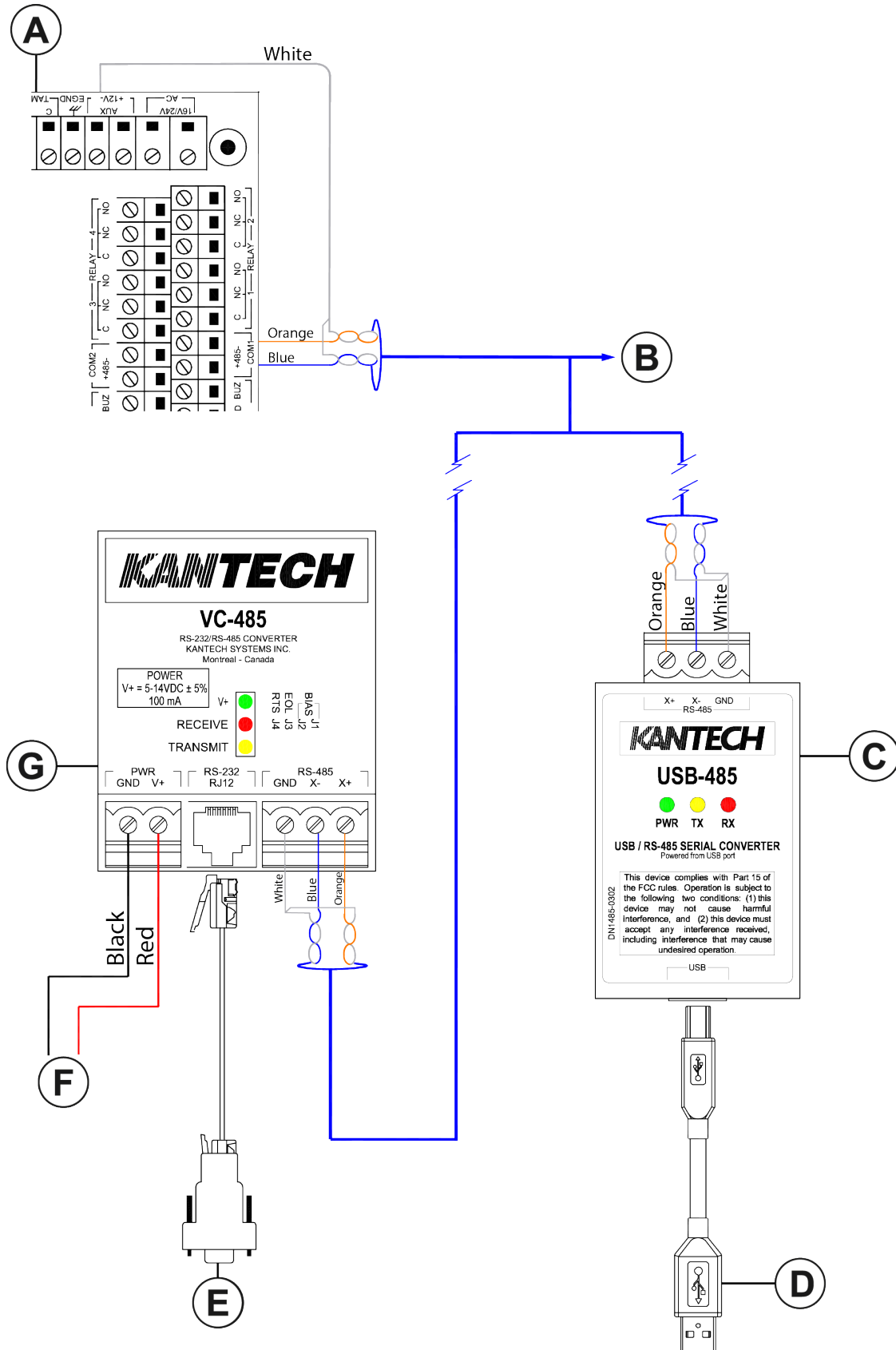

Callout	Description
A	KT-4 controller
B	Connect the RS-485 main network to other KT-4 controllers using the RS-485 interface. There is up to 4000 ft (1.2 km) from the communication interface to the last controller.
C	USB-485: USB to RS-485 serial communication interface. Use for optimal performance with EntraPass Special Edition and Corporate Edition.
D	Computer EntraPass Gateway USB port. The maximum length of the cable is 3.3 ft (1 m).
E	DB9F: Gateway serial port. The maximum length of the cable is 98.5 ft (30 m).
F	External power supply: 5 to 14 VDC 100 mA
G	VC-485: RS-232 to RS-485 serial communication interface. <ul style="list-style-type: none"> <li>Use for optimal performance with EntraPass Global Edition.</li> <li>Do not connect the GND white wire at the VC-485 when using a VC-485.</li> </ul>

## Making an RS-232 cable with an RJ-12 connector

To make your own RS-232 cable with an RJ-12 connector, see the following figure which shows an example of the configuration.

**Figure 14: RJ-12 pin-out**

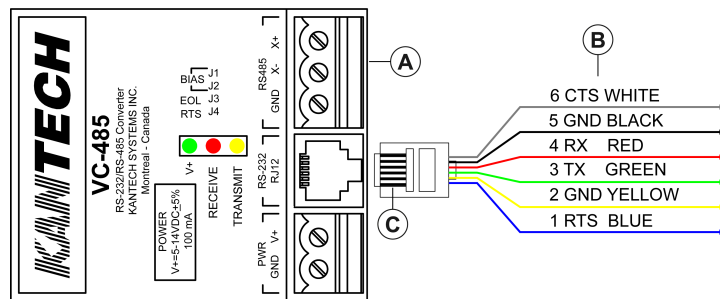

Callout	Description
A	VC-485
B	RJ-12 straight male connector, clip down
C	PIN 1

## Powering the KT-4

- **Important:** Do not apply power to the KT-4 controller until after you complete and test all connections, and after you mount the unit to the wall.
- **Important:** Do not connect the KT-4 controller to the PoE or PoE++ injector and to an external 12 VDC power supply at the same time.

To power the controller, complete one of the following procedures:

### Powering the KT-4 using PoE+ or PoE++

- During the installation, connect the Ethernet wire to the RJ-45 connector.
  - ⓘ **Note:** Use PoE+ or PoE++ Phihong model POE90U-1BT-1.
  - ⓘ **Note:** Do not use PoE+ or PoE++ if you intend to use the KT-4 as a wireless controller.

## Powering the KT-4 using an external transformer

1. Ensure you have a 16.5 or 24 VAC 75 VA transformer.
  2. Place the batteries in the cabinet.
  3. Connect the KT-4 AC power input to the transformer output, and connect the batteries.
- ❗ **Note:** If the AC supply is removed, the 12 VDC 7 Ah backup batteries support normal operation for up to 12 hours if fully charged. If the battery voltage level falls below 9.5 V, then the internal battery verification stops the battery power.
- ❗ **Note:** The KT-4 does not start on battery power only.

## Powering the KT-4 using an internal transformer

1. Place the batteries in the cabinet.
  2. Connect the mains to the neutral and live terminal block.
  3. Connect the KT-4 AC power input to the transformer output, and connect the batteries.
- ❗ **Note:** If the AC supply is removed, the 12 VDC 7 Ah backup batteries support normal operation for up to 12 hours if fully charged. If the battery voltage level falls below 9.5 V, then the internal battery verification stops the battery power.
- ❗ **Note:** The KT-4 does not start on battery power only.

**Figure 15: Powering the KT-4 using an internal transformer**

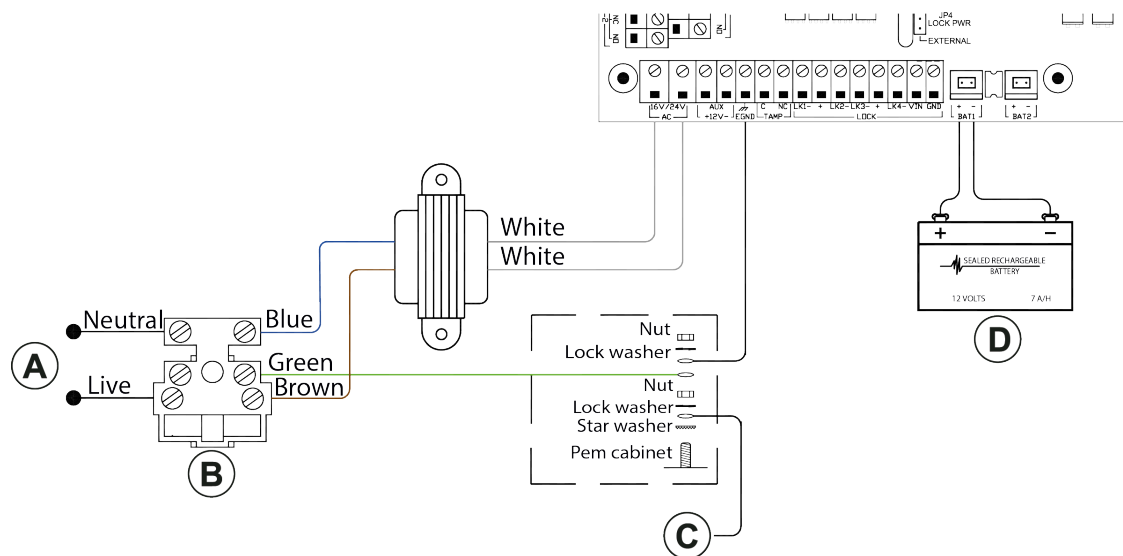

Callout	Description
A	Mains: 230 VAC, 100 VA, 50 Hz
B	Fuse: 20 mm, 230 VAC, slow blow 630 mA, time-lag TUV or VDE approved
C	Ground wire from building electrical installation
D	Main battery: 12 VDC, 7 A/H, KT-BATT-12

# Reset options

The KT-4 has four reset options:

- [Soft reset](#)
- [Hard reset](#)
- [Forced default static](#)
- [Factory default DHCP](#)

To reset the controller, see [Resetting the KT-4](#).

## Soft reset

If you perform a soft reset on a KT-4, the following occurs:

- If all of the controller's memory definitions and parameters are valid, they are verified and kept intact. If they are not valid, the controller goes into a hard reset.
- If it is valid, the internal event buffer is maintained.
- If it is defined, the previous IP address is kept.
- You see one of the following messages: **Power ON Soft Reset**, **Manual Pushbutton Soft Reset**, or **Operator Soft Reset**.
- The input alarm status is maintained unless it was changed during the restart.
- Relay energizing (physical) state is maintained even if the relay LED goes off.
- The LED pattern does not change during the reset.

**Table 6: Soft reset LED pattern**

EntraPass Edition	Communication state	LED pattern
All editions	Offline	Fast flashes
Global Edition	Online	1 flash every second
Corporate Edition	Online	3 flashes every second

## Hard reset

If you perform a hard reset on a KT-4, the following occurs:

- All of the controller's memory definitions reset to their default values.
- The internal event buffer clears.
- If they are used, the IP address and Wi-Fi configuration are kept.
- The LED pattern is in a hard reset state: 4 flashes every second, if it is not in a factory default or forced default static state.
- You see the following message: **Controller Hard Reset**.
- The internal real time clock (RTC) and clock reset to the default time and date values of January 1st 2014, 00:00:00, Wednesday.

## Forced default static

If you perform a forced default on a KT-4, the following occurs:

- If all of the controller's memory definitions and parameters are valid, they are verified and kept intact. If they are not valid, the controller goes into a hard reset.
- If it is valid, the internal event buffer is maintained.
- The IP address resets to the default static IP: 192.168.1.2 Subnet mask: 255.255.255.0.

- You see one of the following messages: **Power ON Soft Reset**, **Manual Pushbutton Soft Reset**, or **Operator Soft Reset**.
- The LED pattern remains in forced default static mode: a flashing beat of 3 reversed flashes, until the controller resets to another mode.

**Note:** When the LED is normally on and flashes off, it is a reversed flash.

## Factory default DHCP

The KT-4 default DHCP is completed by Kantech. Reset the controller to factory default DHCP only for the following reasons:

- To configure the KT-4 with the KT-Finder. For more information, see [Configuring the KT-4 using the KT-Finder](#).
- To change the KT-4 communication port.

If you perform a factory default on a KT-4, the following occurs:

- All of the controller's memory definitions reset to their default values.
- The internal event buffer clears.
- The LED pattern is a reversed flash continuous beat.
- You see the following message: **Controller Factory Default Reset**.
- The internal RTC and clock reset to the default time and date values of January 1st 2022, 00:00:00, Saturday.
- EntraPass configures the controller by communicating through an Ethernet or RS-485 communication port. Over Wi-Fi, the controller automatically performs an antenna calibration, reverts to access point mode, and waits for its configuration from the default web page.

## Resetting the KT-4

1. In the upper left of the main board, locate the **Reset** button. See [Figure 16](#).
2. Complete one of the following reset options:
  - Soft reset: Press **Reset** for less than 2 seconds.
  - Hard reset:
    - i. Press and hold **Reset** for 3 seconds, then you hear 5 beeps.
    - ii. Press **Reset** once.
    - iii. Press and hold **Reset** for 3 seconds, then you hear 5 beeps.
  - Forced default static:
    - i. Press and hold **Reset** for 3 seconds, then you hear 5 beeps.
    - ii. Press **Reset** twice.
    - iii. Press and hold **Reset** for 3 seconds, then you hear 5 beeps.
  - Forced default DHCP
    - i. Press and hold **Reset** for 3 seconds, then you hear 5 beeps.
    - ii. Press **Reset** three times.
    - iii. Press and hold **Reset** for 3 seconds, then you hear 5 beeps.

**Figure 16: KT-4 reset**

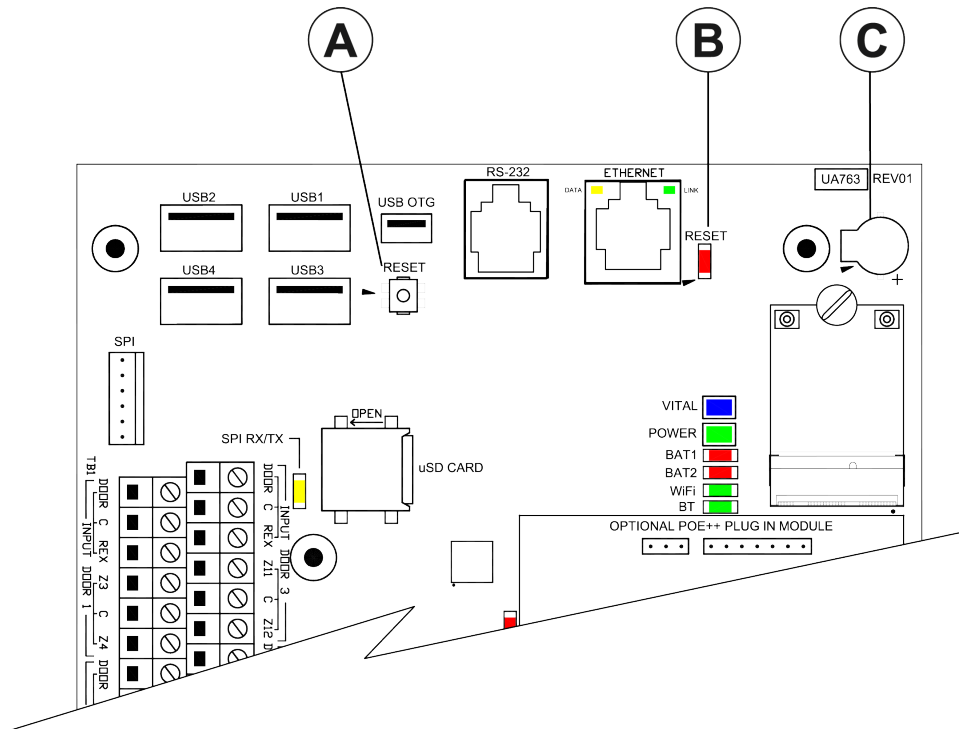

Callout	Description
A	Reset switch <ul style="list-style-type: none"> <li>• Press = soft reset</li> <li>• Hold for 3 seconds                             <ul style="list-style-type: none"> <li>- 1 hit = hard reset</li> <li>- 2 hits = static IP</li> <li>- 3 hits = factory default</li> </ul> </li> <li>• Hold for 3 seconds to confirm</li> </ul>
B	Reset feedback LED
C	Buzzer

## SPI expansion port

Use the Serial Peripheral Interface (SPI) expansion port on the KT-4 to connect expansion modules in order to add more inputs and outputs, such as relays. The maximum current draw for the SPI expansion port is 500 mA when not using the 12 V AUX terminals. You must connect the 6-pin SPI cable to the SPI IN of the first module. See [Figure 17](#) for examples of interconnection between the KT-4 and expansion modules.

**Note:** You cannot extend the SPI wires on the connector.



Figure 17: KT-4 expansion modules

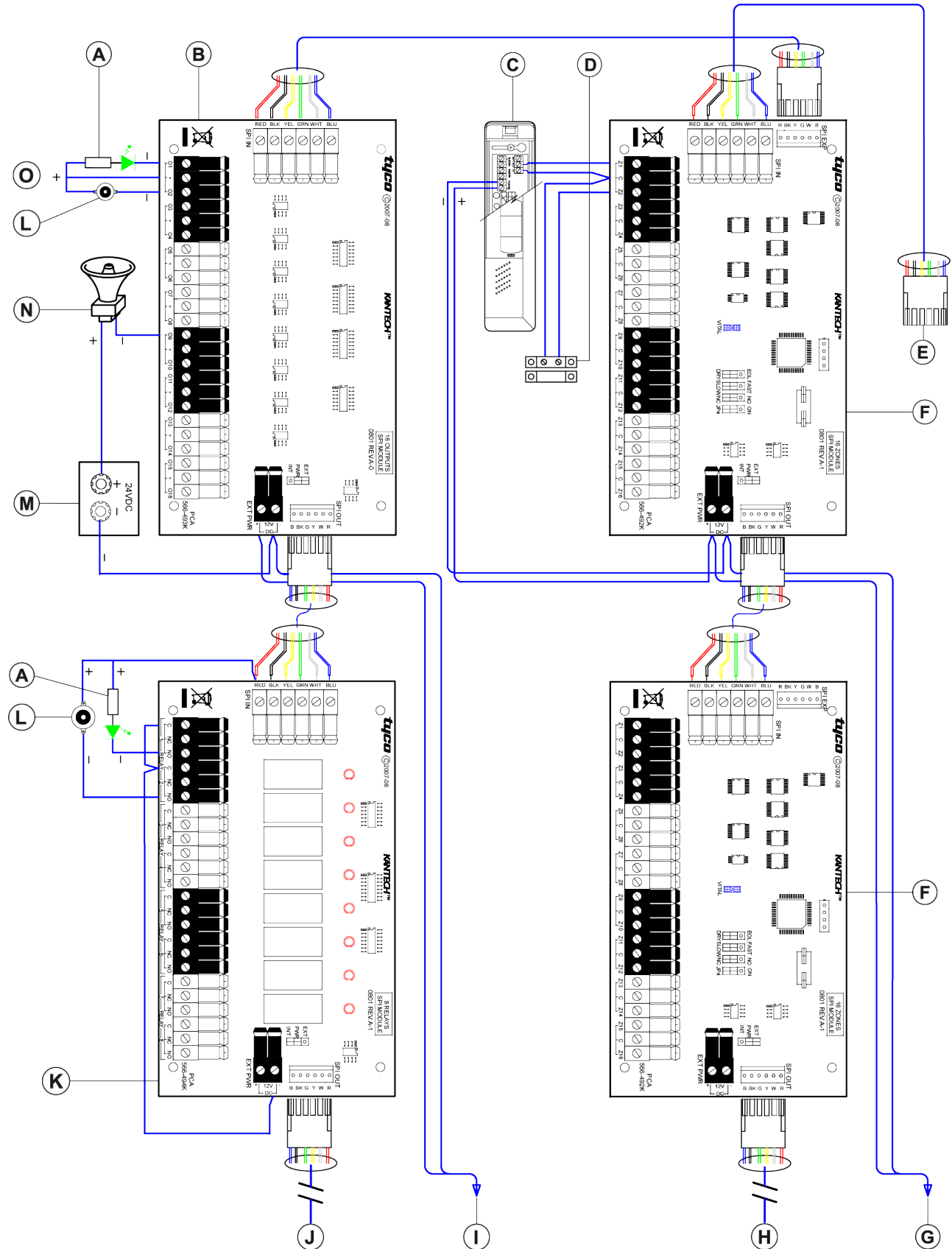

<b>Callout</b>	<b>Description</b>
A	LED
B	Open drain output module
C	Motion detector: 12 VDC power
D	Contact
E	Connect to KT-4 controller
F	Input module
G	Regulated supply 12 V / 0.5 A from external source for all 16-input modules
H	SPI OUT: connection to other input submodule
I	Regulated supply 12 V / 1 A from external source for every 3 relay modules
J	SPI IN EXT: connection to other output submodule
K	Relay module
L	Buzzer
M	Optional external high power source: 12-24 VDC
N	Output device: 5-24 VDC, 1 A maximum
O	12 VDC, up to 0.75 A absolute total outputs, internal or external supply

# Configuration

To configure a controller, complete the steps in one of the following procedures:

- To configure standalone mode, complete [Connecting the KT-4 using the registration page](#).
- To configure EntraPass mode, complete one of the following procedures:
  - [Connecting the KT-4 using the registration page](#)
  - [Configuring the KT-4 using the KT-Finder](#)

To configure a wireless controller, complete [Connecting and configuring a wireless controller](#).

## Connecting the KT-4 using the registration page

### About this task:

Use the KT-4 web interface to connect and set up the KT-4 controller.

1. Determine your connection to the KT-4 and choose the appropriate network cable.
2. On your computer or mobile device, open a web browser.
  - ① **Note:** If you use a mobile device, connect it to a wireless network that has access to the wired network subnet.
3. In the address bar, type `https://KT` and the last six digits of the controller's Ethernet MAC address in the following format: `https://KT-XX-YY-ZZ`.
  - ① **Note:** Ensure that the KT-4 controller and the device you use to access the registration page are on the same network. If either of the devices are behind a bridged network, even if they have the same subnet, this step does not work.
4. On the **KT-4 Registration** page, to configure the correct mode, complete the steps in one of the following procedures:
  - To configure the controller in stand-alone mode, complete one of the following options:
    - [Configuring stand-alone mode using the activate now option](#)
    - [Configuring stand-alone mode using the other ways to activate option](#)
  - To configure the controller in EntraPass mode, complete [Configuring EntraPass mode](#).

### Configuring stand-alone mode using the activate now option

1. On the **KT-4 Registration** page, click **Standalone**.
2. On the **Activate now** tab, in the **Customer information** and **Installer information** fields, enter the relevant information.
3. At the bottom of the page, click **Activate now**.

### Configuring stand-alone mode using the other ways to activate option

1. Contact Kantech technical support in your region to get an activation code.
2. On the **KT-4 Registration** page, click **Standalone**.
3. Click the **Other ways to activate** tab.
4. In the **Activation code** field, enter the activation code.
5. At the bottom of the page, click **Activate now**.

### Configuring EntraPass mode

1. On the **KT-4 Registration** page, click **EntraPass**.
2. In the **EntraPass gateway** pane, in the **IP address** field, type the IP address, or in the **Domain name** field, type the domain name.

3. From the **Protocol** list, select **TCP** or **UDP**.
4. **Optional:** If you select **UDP**, in the **Port** field, type the port number.
5. Click **Submit**.

## Configuring the KT-4 using the KT-Finder

Download the KT-Finder for free from <http://www.kantech.com>. Use the KT-Finder application to configure the controller over the LAN or the WAN.

**Note:** If you connect to Wi-Fi, use the STA MAC address not the AP.

1. Exit all EntraPass applications and services.
2. Reset the KT-4 to factory default DHCP mode. For more information, see [Resetting the KT-4](#).
3. To open the KT-Finder, go to **Start >All Programs>EntraPass Edition>Server>KT-Finder**.
  - Note:** If you try to open the KT-Finder when EntraPass Gateway is open, an error message appears.
4. In the **KT-Finder Wizard** window, from the **Device** list, click **KT-4**.
5. In the **MAC address** field, type the MAC address of the KT-4, and click **Connect**. When the KT-Finder finds the controller, the following message appears: **Configuring the KT-4 with the KT-Finder**.
6. In the **EntraPass Gateway** pane, in the **EntraPass IP Address** field, type the IP address. For more information, refer to the *EntraPass Administrative Guide*.
7. In the **Ethernet configuration** pane, from the **Protocol** list, select **UDP** or **TCP**.
8. **Optional:** If you select **UDP**, in the **Port** field, type the port number.
  - Note:** Change the port number only if you have more than one KT-4 controller at the same remote site.
9. Click **OK**.
10. Repeat the steps for each controller at the site.

## Connecting and configuring a wireless controller

You can connect the KT-4 over Wi-Fi when using the Wi-Fi module option with the provided external antenna mounted and powering the controller through its integrated power supply.

1. On a laptop or mobile device, go to the Wi-Fi settings.
2. Create a new Wi-Fi connection with the following information:
  - **Network name (SSID):** KT4-XX-XX-XX. XX-XX-XX represents the last six digits of the access point (AP) MAC address printed on the KT-4 label.
  - **Security type:** WPA2-Personal AES
  - **Security key:** TYCO1234
  - **Connect even if this network is not broadcasting:** Enabled
3. Click **Save**.
4. From the list of available wireless networks, select the network you created and click **Connect**.
5. On a web browser address bar, type the following IP address: 192.168.240.1/jciprov.html. Press **Enter**.
6. On the **Web Provisioning** page, from the **Please Select Country** list, select a country.

**Note:**

- To change the selected country after you complete the configuration, you must factory default the controller. All saved settings and data are lost when you factory default the controller.
- The list of supported countries may vary depending on regulatory and standards updates.

7. In the **Wireless Network** pane, click **Select Network from List** and select the appropriate network, or click **Manually** and type the name of the network if it is hidden.
8. In the **Password** field, type the network password.
9. In the **EntraPass gateway** pane, click **EntraPass IP address**, and type the direct IP address. Alternatively, leave the IP address as **0.0.0.0** if you want to enroll the controller using the KT-Finder.

**Note:** To avoid connectivity issues, ensure that the controller and the gateway are on the same subnet, and that all the required ports are open in the firewall.

10. From the **Protocol** list, select **TCP** or **UDP**. Before you configure the protocol, ask your network administrator about the firewall rules for communicating over your selected protocol.
11. **Optional:** If you select **UDP**, in the **Port** field, type the port number. Before you configure the port, ask your network administrator about the firewall rules for ports.
12. Click **Submit**.

### Result

- If the controller succeeds in joining the selected wireless network, the Wi-Fi LED turns on and is solid green.
- If the controller fails to connect, the Wi-Fi LED stays off. The controller attempts to connect three times before returning to AP mode (factory default).

## KT-4 models, expansion kits, and related items

The following table lists all of the KT-4 controller models, expansion kits, and miscellaneous, related items.

**Table 7: KT-4 models, expansion kits, and related items**

Part number	Description
KT-4-EU	KT-4 four-door IP controller, global model metal cabinet, accessory kit, and lock
KT-4-PCB	KT-4 four-door controller, PCB only, IP ready, and accessory kit
KT-4	KT-4 four-door controller, IP ready, accessory kit, and metal cabinet with lock
KT-ACC	Generic Kantech accessory kit
KT-4-CAB	KT-4 black metal cabinet with lock
KT-4-CABEU	KT-4 global model black metal cabinet with lock
KT-CON	Generic Kantech connector kit
KT-4-MOD-WIFI	KT-4 optional Wi-Fi module, M.2 mounting screw, antenna, and knockout plug kit
KT-4-MOD-POE	KT-4 optional PoE module with mounting standoff
KT-4-POE	KT-4 IP controller with PoE module

**Table 7: KT-4 models, expansion kits, and related items**

<b>Part number</b>	<b>Description</b>
KT-4-WIFI	KT-4 IP controller with Wi-Fi
USB-485	USB-485 interface, USB cable 0.9 m (3 ft), and USB drivers on CD-ROM
VC-485	VC-485 interface, RS-232 cable 3 m (10 ft) with RJ-12 connectors, 740-1012 (DB25F to RJ-12) adapter, 740-1022 (DB9F to RJ-12) adapter and 740-1033 (DB25M to RJ-12) adapter
TR1675	KT-4 transformer, wire-in, 110 VAC/16.5 VAC (75 VA), UL approved
TR161000	KT-4-EU transformer, wire-in, 240 VAC/16 VAC (100 VA), CE approved
KT-4-BATASSY	KT-4 battery leads with connector
KT-BATT-12	Rechargeable battery, 12 VDC, 7 AH, optional
KT-MOD-IO16	RS-485 Input/Output Module
KT-MOD-INP16	Expansion module 16-zone input with SPI cable (KT-MOD-SPI-16)
KT-MOD-OUT16	Expansion module 16-output with SPI cable (KT-MOD-SPI-16)
KT-MOD-REL8	Expansion module 8-relay with SPI cable (KT-MOD-SPI-16)

## KT-4 maintenance recommendations

### ► **Important: Only a service person shall perform the following maintenance.**

The KT-4 includes a lithium CR2032 primary battery. See Figure 1. This battery must be replaced by **a service person ONLY** to avoid any risk of explosion. If the lithium battery stops working, contact the service person for maintenance if the lithium battery voltage measures below 2.75 VDC. Do not crush, puncture, open, disassemble or otherwise mechanically interfere with the battery. Do not try to recharge the battery. If you need to dispose of the PCB and/or the lithium battery, wrap the KT-4 in non-conductive tape. Check with your local authorities for battery disposal regulations.

▲ **WARNING:** Do not store the batteries in such a way that they come into contact with each other or with any piece of metal. Explosion or fire may occur. Should fire occur, use only dry chemical fire extinguishers. Do not use water to put out the fire. Do not heat the batteries. Do not dispose of the batteries or PCB in a fire. Do not disassemble the batteries. Do not apply pressure to or deform the batteries. Ensure that the above precautions are strictly observed by related departments, including, but not limited to, production, sales and outside contractors.

Regarding the recommended backup battery 12 VDC / 7 Ah: It is the service person's responsibility to assure that the disposal of used batteries is made according to the waste recovery and recycling regulations applicable to the intended market. Use the recommended battery type **ONLY**. It is strongly advised to have the following tests performed by **service persons ONLY**:

#### 1. **Biannual test for battery:**

Remove AC power from the controller and let it work on battery backup power for 30 minutes. This test will ensure that in the event of a power failure, the battery will be able to support normal operations. This test should be performed twice a year. Once the test has been performed successfully, reconnect AC power to the controller.

#### 2. **Annual test for emergency lithium battery:**

Measure voltage of lithium battery when power is totally removed from the controller (AC, DC and backup battery power). To ensure maximum operation and to prevent loss of the database, contact your KT-4 distributor to return the controller for maintenance if the lithium battery voltage measures below 2.75 VDC.

## Technical support

See the following technical support contact details and opening hours in your region, or go to: [https://kantech.com/Support/Contact\\_Technical\\_Support\\_Advanced.aspx](https://kantech.com/Support/Contact_Technical_Support_Advanced.aspx).

### United States and Canada

**Table 8: United States and Canada telephone numbers**

Region	Call type	Business hours: 08:00 to 20:00 (EST)
United States and Canada	Toll free	+1 888 222 1560
United States and Canada	Toll free	+1 800 507 6268 option 4

### Latin America and Caribbean

For technical support, contact us at one of the following email addresses or use the phone number for your region.

- For access technical support, email [access-support@jci.com](mailto:access-support@jci.com).
- For video technical support, email [video-support@jci.com](mailto:video-support@jci.com).

- For technical training inquiries, email [latam.certificaciones@jci.com](mailto:latam.certificaciones@jci.com).

**Table 9: Latin America and Caribbean telephone numbers**

Region	Call type	Business hours: 08:00 to 20:00 (EST)
Latin America and Caribbean	Toll free	+1 800 507 6268
Latin America and Caribbean	Toll free	+1 800 392 2873
Argentina, Buenos Aires	Direct	+54 11 5199 3104
Brazil, Sao Paulo	Direct	+55 11 3181 7377
Chile, Santiago	Direct	+56 2 3210 9662
Colombia, Cali	Direct	+57 2 891 2476
Colombia, Medellin	Direct	+57 4 204 0519
Costa Rica, National VOIP	Direct	+506 4 000 1655
Dominican Republic, Santo Domingo	Direct	+1 829 235 3047
El Salvador, San Salvador	Direct	+503 2 136 8703
Guatemala, Guatemala City	Direct	+502 2 268 1206
Mexico, Mexico City	Direct	+52 55 8526 1801
Panama, Panama City	Direct	+507 836 6265
Peru, Lima	Direct	+51 1 642 9707
Venezuela, Caracas	Direct	+58 212 720 2340

## Europe, Middle East, and Africa

For technical support, contact us at one of the following email addresses or use the phone number for your region.

- For technical post-sales inquiries, email [video-support@jci.com](mailto:video-support@jci.com).
- For technical training inquiries, email [emea.training@jci.com](mailto:emea.training@jci.com).
- For all licensing inquiries, email [sp-licensing-support@jci.com](mailto:sp-licensing-support@jci.com).

**Table 10: Europe, Middle East, and Africa telephone numbers**

Region	Call type	Business hours: 08:00 to 18:00 (CET)
Europe, Middle East, and Africa	Toll free	+800 2255 8926
Europe, Middle East, and Africa	Direct	+31 475 352 722
Bahrain	Direct	(0)800 04127
Belgium	Direct	+0800 76 452
Denmark	Direct	+45 4494 9001
France	Direct	+0800 90 79 72
Germany	Direct	+0800 1806 757
Greece	Direct	00800 312 294 53
Ireland	Direct	+1800 94 3570
Israel	Direct	+972 772 201 350
Italy	Direct	+39 0230 510 112
KSA	Direct	+96 6800 8500 509
Kuwait	Direct	(0)22062915
Lebanon	Direct	01 426 801, new dial tone and then dial 8552 3436 77



**Table 10: Europe, Middle East, and Africa telephone numbers**

Region	Call type	Business hours: 08:00 to 18:00 (CET)
Nordic Countries	Direct	04494 9001
Oman	Direct	(00) 8007 4364
Qatar	Direct	(00) 800100841
Russia	Direct	81 0800 2052 1031
South Africa	Direct	+27 (0) 10 100 3292
Spain	Direct	+900 99 31 61
Turkey	Direct	+00800 3192 3007
United Arab Emirates	Direct	(0)800 0310 7123
United Kingdom	Direct	+44 330 777 1300

## Asia Pacific

For technical support, contact us at one of the following email addresses or use the phone number for your region.

- For video technical support, email [video-support@jci.com](mailto:video-support@jci.com).
- For technical training inquiries, email [apac.training@jci.com](mailto:apac.training@jci.com).
- For all licensing inquiries, email [sp-licensing-support@jci.com](mailto:sp-licensing-support@jci.com).

**Table 11: Asia Pacific telephone numbers**

Region	Call type	Business hours: 09:00 to 18:00 (CST China Standard Time) and 09:00 to 19:00 (IST India Standard Time)
Asia Pacific	Toll free	+ 800 2255 8926
Australia	Direct	+1 800 580 946
China	Direct	+86 21 6163 8644
India	Direct	+91 80 4199 0994
Oceania and New Zealand	Direct	+64 9942 4004

## Compliance specifications

### United States and Canada

This equipment has been tested and found to comply with the limits for a Class B digital device pursuant to Part 15 of the FCC Rules. These limits are designed to provide reasonable protection against harmful interference when this equipment is operated in a commercial environment. This equipment generates, uses, and can radiate radio frequency energy and, if not installed and used in accordance with the instruction manual, may cause harmful interference to radio communications.

Operation of this equipment in a residential area may cause harmful interference, in which case users will be required to correct the interference at their own expense.

### Warning (Part 15.105)

This equipment has been tested and found to comply with the limits for a Class B digital device, pursuant to part 15 of the FCC Rules. These limits are designed to provide reasonable protection against harmful interference in a residential installation. This equipment generates, uses and can radiate radio frequency energy and, if not installed and used in accordance with the instructions,

may cause harmful interference to radio communications. However, there is no guarantee that interference will not occur in a particular installation. If this equipment does cause harmful interference to radio or television reception, which can be determined by turning the equipment off and on, the user is encouraged to try to correct the interference by one or more of the following measures:

- Reorient or relocate the receiving antenna.
- Increase the separation between the equipment and receiver.
- Connect the equipment to an outlet on a circuit different from that to which the receiver is connected.
- Consult the dealer or an experienced radio/TV technician for help.

## RF Transmitters: Compliance Statement (Part 15.19)

This device complies with Part 15 of the FCC Rules. Operation is subject to the following two conditions:

1. This device may not cause harmful interference.
2. This device must accept any interference received, including interference that may cause undesired operation.

## IC Statement

This device complies with Industry Canada licence-exempt RSS standard(s). Operation is subject to the following two conditions: (1) This device may not cause harmful interference, and (2) this device must accept any interference received, including interference that may cause undesired operation of the device. In addition, this device complies with ICES-003 of the Industry Canada (IC) Rules. Any Changes or modifications not expressly approved by the party responsible for compliance could void the user's authority to operate the equipment.

### **Note:**

This equipment has been tested and found to comply with the limits for a Class B digital device, pursuant to Industry Canada licence-exempt RSS standard(s). These limits are designed to provide reasonable protection against harmful interference in a residential installation. This equipment generates uses and can radiate radio frequency energy and, if not installed and used in accordance with the instructions, may cause harmful interference to radio communications. However, there is no guarantee that interference will not occur in a particular installation. If this equipment does cause harmful interference to radio or television reception, which can be determined by turning the equipment off and on, the user is encouraged to try to correct the interference by one or more of the following measures:

- Reorient or relocate the receiving antenna.
- Increase the separation between the equipment and receiver.
- Connect the equipment into an outlet on a circuit different from that to which the receiver is connected.
- Consult the dealer or an experienced radio/TV technician for help.

### **RF Exposure**

This equipment complies with RSS-102 radiation exposure limits set forth for an uncontrolled environment. This equipment should be installed and operated with minimum distance 20cm between the radiator and your body.

Cet appareil est conforme aux normes RSS exemptes de licence d'Industrie Canada. Son fonctionnement est soumis aux deux conditions suivantes : (1) Cet appareil ne doit pas causer d'interférences nuisibles et (2) cet appareil doit accepter toute interférence reçue, y compris les interférences susceptibles de provoquer un fonctionnement indésirable de l'appareil. De plus, cet appareil est conforme à la norme ICES-003 des règles d'Industrie Canada (IC). Tout changement ou modification non expressément approuvé par la partie responsable de la conformité pourrait annuler l'autorité de l'utilisateur à faire fonctionner l'équipement. Remarque : cet équipement a été testé et déclaré conforme aux limites d'un appareil numérique de classe B, conformément aux normes RSS exemptes de licence d'Industrie Canada. Ces limites sont conçues pour fournir une protection raisonnable contre les interférences nuisibles dans une installation résidentielle. Cet équipement génère des utilisations et peut émettre de l'énergie de radiofréquence et, s'il n'est pas installé et utilisé conformément aux instructions, peut causer des interférences nuisibles aux communications radio. Cependant, il n'y a aucune garantie que des interférences ne se produiront pas dans une installation particulière. Si cet équipement cause des interférences nuisibles à la réception radio ou télévision, ce qui peut être déterminé en éteignant et en rallumant l'équipement, l'utilisateur est encouragé à essayer de corriger l'interférence par une ou plusieurs des mesures suivantes :

- Réorientez ou déplacez l'antenne de réception.
- Augmenter la distance entre l'équipement et le récepteur.
- Connectez l'équipement à une prise sur un circuit différent de celui auquel le récepteur est connecté.
- Consultez le revendeur ou un technicien radio/TV expérimenté pour obtenir de l'aide.

Cet équipement est conforme aux limites d'exposition aux rayonnements RSS-102 établies pour un environnement non contrôlé. Cet équipement doit être installé et utilisé avec une distance minimale de 20 cm entre le radiateur et votre corps.

## Warning (Part 15. 21)

Changes or modifications not expressly approved by the party responsible for compliance could void the user's authority to operate the equipment.

## RF Exposure (OET Bulletin 65)

To comply with FCC RF exposure requirements for mobile transmitting devices, this transmitter should only be used or installed at locations where there is at least 20 cm separation distance between the antenna and all persons.

## Canada

This class B digital apparatus meets all requirements of the Canadian Interference Causing Equipment Regulations. CAN ICES-3 (A) / NMB-3 (A).

This radio transmitter 9154-GS2101M has been approved by Industry Canada to operate with the antenna types listed below with the maximum permissible gain indicated. Antenna types not included in this list, having a gain greater than the maximum gain indicated for that type, are strictly prohibited for use with the KT-4.

**Table 12: Antenna type**

Antenna type	Antenna gain at 2.4 GHz and 5 GHz
Dipole with I-PEX connector	2.0 dBi

## CE, RCM, & UKCA

Australia/New Zealand: RCM Compliance.

European Union: KT-4-EU complies with Radio Equipment Directive.

United Kingdom: KT-4-EU complies with Radio Equipment Regulations.

## UL

To comply with UL listings, the following requirements must be met:

- Use of a UL listed computer
- Use of UL listed readers (Wiegand 26 and 34 bits, mag stripe 26 and 34 bits, XSF 39 bits have been tested and found to comply)
- Use of a UL recognized tamper switch on every housing cabinet for the KT-4 Four-Door Controller
- Do not use the SmartLink option
- Do not use a 230 VAC transformer (not UL listed)
- Use only UL listed cables
- Use only UL listed adaptors
- Use only a UL listed transformer Hammond BF2F or BF2G such as Kantech part number TR1675 or TR 2475 (available through Kantech distributors or dealers, please refer to the Technical Support contact information on page 2 to obtain the specific transformer)
- The KT-4-EU has not been validated as a UL Listed system.
- The KT-CAB3000LDR and KT-CAB4000LDR have been evaluated by UL as alternate enclosures.
- The KT-MOD-IO16 has not been evaluated.

**Note:** All circuits are power limited.

To set up audible and/or visual signals in EntraPass, complete the following procedures:

### Creating a task builder action for audible and visual signals in EntraPass

1. On the EntraPass main menu, click the **Definition** tab, and click **Task Builder**.
2. In the **Task Builder** window, click the **New** icon.
3. In the **English** field, enter a name for the task.
4. Click **Command**.
5. To set up an audible signal, complete the following steps:
  - a. In the **SmartLink Task Builder** window, from the **Component Type** list, select **Relay**.
  - b. From the **Command** list, select a relay action, for example **Toggle relay activation**.
  - c. From the **Component** List, select a relay on the KT-4 controller.
6. To set up a visual signal, complete the following steps:
  - a. In the **SmartLink Task Builder** window, from the **Component Type** list, select **Relay**.
  - b. From the **Command** list, select a relay action, for example **Toggle relay activation**.
  - c. From the **Component** List, select a relay on the KT-4 controller.
7. Click **OK**.
8. Click **Save** and close the window.

**Note:** Audible and visual signaling devices must be connected to the KT-4 relays and located near to the KT-4 controller. Depending on the audible or visual device you use, you may require an external power supply.

## Creating a trigger and alarm sound in EntraPass

1. On the EntraPass main menu, click the **Devices** tab and click **Controller**.
2. From the **Controller** list, select the controller.
3. Click the **Trigger and Alarm** tab.
4. Right-click and select **New trigger**.
5. In the **Trigger and Alarm** window, in the **English** field, enter a name for the trigger.
6. On the **General** tab, from the **Component Type** list, select **Controller**.
7. From the **Controller** list, select the controller.
8. From the **Trigger schedule** list, select **Always valid**.
9. From the **Task Builder** list, select the task that you created in [Creating a task builder action for audible and visual signals in EntraPass](#).
10. On the **Events** tab, click **Controller communication failed**.
11. On the **Alarm notification** tab, from the **Alarm schedule** list, select **Always valid**.
12. From the **Desktop alarm** list, select **Always valid**, and click the **Save** icon.
13. To create an alarm sound, complete the following steps:
  - a. On the EntraPass main menu, click the **Options** tab and click **Multimedia Device**.
  - b. On the **Sound** tab, from the **Priority** list, select the priority level associated with the event **Controller communication failed**. The default is priority level 3.
  - c. Click **Assign alarm sound** and select an alarm sound from the list.
  - d. Click **OK**.
14. On the EntraPass main menu, click the **Desktops** tab, right-click one of the eight desktop views and select **Properties**.
15. In the **Desktop properties** window, in the **Alarms Desktop** pane, select **Messages screen** and click **OK**.

When a controller's communication fails, a message displays in the desktop view and an alarm sounds.

To comply with UL listings, the following requirements must be met:

- Installation locations and wiring methods shall be in accordance with the National Electrical Code, ANSI/NFPA 70.
- Do not connect to a receptacle controlled by a switch.
- Use of a UL 60950 or UL 62368 listed computer.
- Use of a UL recognized tamper switch on every housing cabinet for the KT-4 Four-Door Controller.
- Do not use the SmartLink option.
- Do not use a 230 VAC transformer (not UL listed).
- Use only UL listed cables.
- Use only UL listed adaptors.
- Use only a UL listed transformer Hammond BF2F or BF2G such as Kantech part number TR1675 or TR 2475 (available through Kantech distributors or dealers, please refer to the [Technical support](#) contact information to obtain the specific transformer).
- The KT-4-EU has not been validated as a UL Listed system.
- Security hardening guide has not been evaluated by UL.

- ① **Note:** All circuits are power limited with the exception of the battery wire connection. Separation of 3/4 in. shall be maintained between power limited and non-power limited wiring.
- ① **Note:** Replace lithium battery with Changzho Jintan Chaochuang Battery Co Ltd., Panasonic or Energizer Part No. CR2032 Only. Use of another battery may present a risk of fire or explosion.

### UL 294 Compliance Notice

- Use only UL 294 or UL 1076 listed power supply.
- Connect Kantech part number KT-ACPW-LED status indicator to the AC terminals of the KT-PS4085.
- Connect Kantech part number KT-ACPW-LED status indicator to the AC terminals of the KT-4.
- Use a Kantech battery, part number KT-BATT-12, for a minimum of 2 hours of backup battery power.
- The following UL Listed readers may be used: P225W26, P225KPW26, P225XSF, P225KPXSF, P325W26, P325KPW26, P325XSF, P325KPXSF, P600, KT-MUL-SC, KT-SG-SC, KT-SG-SC-KP, KTMUL-SC-KP, KT-MUL-MT, KT-SG-MT, KT-SG-MT-KP, KT-MUL-MT-KP; HID Signo 20NKS, 20TKS, 20KNKS, 20KTKS, 40NKS, 40TKS, 40KNKS, 40KTKS.
- Communication between EntraPass and the KT-4 shall use a secure network to guard against such threats as: Denial of Service (DoS), spoofing, sniffing, hijacking, Trojans, viruses/worms, and malware.

**Table 13: UL 294 performance levels**

Model	Destructive attack	Line security	Endurance	Standby power
<b>KT-4</b>	Level I	Level I	Level IV	Level IV
<b>KT-4-PCB</b>	Level I	Level I	Level IV	Level IV
<b>KT-4-CAB</b>	Level I	Level I	Level IV	Level IV
<b>KT-4-MOD-WIFI</b>	Level I	Level I	Level IV	Level I
<b>KT-4-MOD-POE</b>	Level I	Level I	Level IV	Level I
<b>KT-4DE2 KT-4DNE2 KT-4DE2-WPA KT-4DNE2-WPA KT-8DE4 KT-8DNE4 KT-8DE4-WPA KT-16DE6 KT-16DNE6 KT-16DE6-WPA KT16DNE6-WPA</b>	Level I	Level I	Level IV	Level IV

### UL 2610 Compliance Notice

- The KT-4 is UL 2610 Listed as a Commercial Proprietary Control Unit Accessory and Proprietary Burglar Alarm Unit (Section 83.2), with EntraPass and Redundant Server, alarm system features, EOL, KT-400 Controllers, Kantech ioProx Proximity readers, and TReX request to exit devices – other sensor devices (temperature, water level, etc.) may be used as long as they are also UL 2610 Listed.
- The KT-4-POE is not validated for UL 2610

- The EntraPass and Redundant Server shall be running at all time, and manned 24 hours a day, 365 days a year – The EntraPass and Redundant Server will each have their own operator workstation.
- Data processing equipment and office appliance and business equipment used as central supervisory equipment station shall be listed to Information Technology Equipment - Safety-Part 1: General Requirements - UL 60950-1 or UL 62368-1.
- Should the EntraPass and/or Redundant Server be replaced, a UL 60950-1 or UL 62368-1 listed computer must be used.
- The following recommended system requirements apply to the EntraPass Server, Redundant Server, Video Vault, Card Gateway, SmartLink, and Workstation:
  - Operating Systems: Windows® 2008/Windows 2012/Windows 7 Standard/Enterprise Server Editions/Windows 8/Windows 10
  - Processor: Dual Core
  - 4 GB RAM
  - Minimum free hard disk space: 20 GB
  - Color depth: 24-bit (16 million colors), required for Video Integration only
  - Screen resolution: 1024 x 768
  - AGP or PCI Express 8X graphics card with 64 MB memory and DirectX 9.0 support
  - Network Interface card: 10/100 Base-T network adaptor
- ⓘ **Note:** Actual requirements may vary based on your operating system and configuration.
- The Central Supervisory Equipment shall employ supply line transient protection complying with the Standard for Transient Voltage Surge Suppressors, UL 1449, with a maximum marked rating of 330 V.
- The Central Supervisory Equipment shall employ signal line Transient protection complying with the Standard for Protectors for Data Communications and Fire Alarm Circuits, UL 497B, with a maximum marked rating of 50 V.
- The Central Supervisory Equipment shall employ that communication circuits and network components connected to the telecommunications network shall be protected by secondary protectors for communication circuits. These protectors shall comply with the Standard for Secondary Protectors for Communications Circuits, UL 497A. These protectors shall be used only in the protected site of the telecommunications network.
- The Central Supervisory Equipment shall be installed in a temperature controlled environment. A temperature controlled environment is defined as one that can be maintained between 13° - 35°C (55° - 95°F) by HVAC system. Twenty-four hours on standby power shall be provided for the HVAC system. The standby power system for the HVAC system may be supplied by an engine driven generator alone. A standby battery is not required to be used.
- A marking to identify the application and signaling function of the product is located on the inside of the unit (inner door sticker).
- For certified commercial proprietary control unit accessory applications, the requirements of UL 2610, Commercial Proprietary Control Unit Accessory also apply.
- The reader(s), that is(are) designated to arm or disarm the alarm system, must be within the secured side of the customer premises.
- The following Kantech readers have been validated by UL for the UL 2610 Standard: P225W26, P225KPW26, P225XSF, P225KPXSF, P325W26, P325KPW26, P325XSF, P325KPXSF and P600; HID Signo 20NKS, 20TKS, 20KNKS, 20KTKS, 40NKS, 40TKS, 40KNKS, 40KTKS.
- ⓘ **Note:** All P series readers can be ordered with or without the following suffixes: BEI, BEI-SE, GRY, or GRY-SE.



- All alarms shall be reported and acknowledged in the following priority:
  - ① **Note:** To set these priorities, please adjust the Event Parameters, found in EntraPass System.
    - Fire alarm and industrial supervision where a risk of injury to persons, or damage or destruction of property may be involved.
    - Hold-up or panic alarm.
    - Burglar alarm.
    - Watchman tour (Guard tour).
    - Fire-alarm supervision.
    - Burglar-alarm supervision.
    - Industrial supervision where a risk of injury to persons, or damage or destruction of property will not be involved.
- If multiplex system signals are transmitted directly from the protected systems to the central supervising station and the loss of the channel prevents the receipt of signals from protective circuits beyond the fault, the number of separate signals on a single channel shall be limited to 1000.
- Minimum 4 hours of stand-by power provided by a standby rechargeable battery, rated 12V, 7Ah. Loss of AC signal is transmitted immediately to the central station. Required use of Reader's LED (flashing) as acknowledgment signal indicator.
- Use EntraPass and under Definition/Alarm System/Door enable the option "Supervised door when armed" when using the Reader's flashing LED to indicate the acknowledgment signal.
- The PoE+/PoE++ feature is not permitted for UL 2610.
- The supervision of the IP network connection between a KT-4 and EntraPass is controlled by the network pulse time. You can program the network pulse time in EntraPass from 15 seconds up to 10 minutes. The default times are 1 minute for EntraPass Corporate Edition and 15 seconds for EntraPass Global Edition. For UL listed installations, the allowed range for the network pulse time is from 15 seconds up to 140 seconds. The loss of communication notification will occur when the network pulse time has elapsed twice plus 15 seconds.
- Acknowledgment signal (closing signal) is indicated at the user interface reader via a flashing red/green LED. To configure, at EntraPass and under Definition/Alarm System/Door enable the **Supervised door when armed** option.
- AC power on indication shall be provided by Kantech part number ULC-LA.
  - Remove one knock-out from the position on the cabinet where the light assembly will be most visible.
  - Run the light assembly wires through the knockout hole and press the assembly into the opening.
  - Connect the light assembly leads to the KT-PS4085 AC IN terminals.
- KT-4 firmware version is verified at monitoring station (EntraPass) under **Operation>Controller>Full Status**.
- 12 VDC, 7 Ah battery is a gel sealed lead-acid type.
- For UL 2610 standby power compliance, the KT-4 requires the following maximum loading: 500 mA on Aux, 500 mA on Reader, and 1 A non-continuous Door Lock.

## End-User License Agreement

### Software Terms



Use of this software that is in (or constitutes) this product, or access to the cloud, or hosted services applicable to this product, if any, is subject to applicable end-user license, open-source software information, and other terms set forth at <http://johnsoncontrols.com/techterms>. Your use of this product constitutes an agreement to such terms.

## Copyright

© 2024 Johnson Controls. All rights reserved. JOHNSON CONTROLS and KANTECH are trademarks of Johnson Controls.

